

SACRAMENTO CHARTER HIGH SCHOOL

2315 34th Street • Sacramento, CA 95817

Student-Parent Handbook 2016-2017

Sacramento Charter High School Campus

Telephone: (916) 277-6200

Fax: (916) 277-6370

Website: www.sachigh.org

St. HOPE Public Schools

Telephone: (916) 649-7900

Fax: (916) 277-7105

Website: www.sthopepublicschools.org

This handbook belongs to:

Student Name: _____

Please immediately put your name on this handbook when you receive it.

The administration of Sacramento Charter High School reserves the right to amend this handbook at any time. Notification of amendments will be PROVIDED IN WRITING TO STUDENTS AND FAMILIES.

1856 – 2017

The information in this book was the best available at press time. Watch for additional information and changes.



©2016 School Datebooks, Inc. All rights reserved.

No part of this publication may be reproduced, transmitted, transcribed, stored in any retrieval system, or translated in any form without the written permission of School Datebooks, Inc.

2880 U.S. Hwy. 231 S. • Lafayette, IN 47909 • (765) 471-8883

<http://www.schooldatebooks.com> • sdi@schooldatebooks.com

Table of Contents

GENERAL INFORMATION	3
INTRODUCTION AND WELCOME	3
HISTORY	4
VISION	4
MISSION	4
MOTTO	4
SCHOOL PRIDE	4
SAC HIGH'S BIG GOALS FOR STUDENT ACHIEVEMENT	5
SAC HIGH'S EXPECTED SCHOOL-WIDE LEARNING RESULTS (ESLRs)	5
St. HOPE'S AND SAC HIGH'S 5 PILLARS	5
DRAGONS' VALUES	5
COMMITMENT TO EXCELLENCE CONTRACTS	6
TEACHER/STAFF COMMITMENT	6
PARENT(S)/GUARDIAN(S) COMMITMENT	7
STUDENT COMMITMENT	8
GOVERNANCE.....	9
PARENTAL INVOLVEMENT.....	10
PARENT'S RIGHT TO KNOW	10
ALUMNI ORGANIZATIONS	10
2016-17 KEY DATES.....	11
2016-17 SCHOOL CALENDAR	12
2016-2017 BELL SCHEDULE	13
ACADEMIC PROGRAM.....	14
COURSES OF STUDY	14
GRADUATION REQUIREMENTS	16
ACADEMIC POLICIES.....	16
STUDENT SERVICES	19
STUDENT LIFE.....	23
STUDENT ACTIVITIES	23
ATHLETICS.....	25
ATTENDANCE.....	26
STUDENT CONDUCT AND BEHAVIOR	29
STUDENT UNIFORM AND DRESS CODE POLICY	29
STUDENT BEHAVIORIAL EXPECTATIONS	32
DISCIPLINARY PROCEDURES.....	39



Dear Students, Parents and Families:

Welcome to the 2016-2017 school year! We are incredibly excited for the year ahead.

Each member of the Sac High community (students, parents, and school staff) has made an informed Choice to be an integral part of our school, Sacramento Charter High School. Each member has also made a Commitment to do whatever it takes to help ALL Sac High students to prepare for college through developing their academic, character and leadership skills.

We stand at a very special point in time. Educational research clearly states that ALL students, regardless of socio-economic status or ethnicity, can learn when provided with High Expectations, rigorous academic framework, and exceptional teaching. There are NO EXCUSES for students, parents, teachers and school administrators! There are also No Shortcuts on the road to prepare for college. Sac High students are repeatedly confirming this research.

To meet this challenge, students, parents, educators and community members must work collaboratively. We must be able to rely on one another. Our relationships will grow stronger as we build trust and learn to value one another's unique skills and contributions. Ultimately, our relationships and efforts will yield outstanding results in college preparedness as demonstrated by the success of Sac High's students with 4-year College acceptance and enrollment rates.

Sac High has experienced a great deal of success in our first 13 years of operation. The relentless efforts of dedicated students, teachers, staff, and parents have made Sac High one of the highest performing comprehensive high schools in California as the school received 10 out of 10 possible points when compared with all similar high schools across the state. There is even greater excitement as we open the 2016-2017 school year.

Students, please read through this handbook carefully and keep it with you every day so that you may have it available for future reference. This handbook has been designed to communicate the basic policies we all must follow to ensure preparing to earn a four-year college degree remains the focus of each minute of every day.

We look forward to working with you to prepare our students to become lifelong learners and leaders.

For our Students,
The Sac High Team

HISTORY

Established in 1856, Sacramento High School is the second-oldest high school west of the Mississippi. First located at 8th and M streets, the school opened in a rented, one-room building with 39 students. Sacramento High School moved several times before settling at its current location at 34th and Y streets in 1923. This site originally housed a set of two-story brick buildings anchored by a clock tower. In 1976, the modern, earthquake-safe campus used today was completed.

For years Sacramento High School was the only high school in Sacramento and it grew to be quite large. At its peak, the school accommodated 4,000 students. With the opening of C.K. McClatchy High School in 1937, Sacramento High School's student body was split in half, an action that initiated the friendly rivalry the two schools enjoy to this day. The annual Thanksgiving Day football game between the two schools was, for a long time, one of the best-attended events in Sacramento. The coveted "victory bell" continues to be the trophy held by the school winning the annual Sac High-McClatchy football game, known as the Bell Game.

Over the last 160 years, Sacramento High School has graduated many prominent Sacramentans, including former governor and state senator Hiram Johnson; Sacramento's first woman mayor, Belle Coolidge; and Sacramento's current mayor, Kevin Johnson.

On September 2, 2003, Sacramento Charter High School (Sac High) opened as an independent public charter school managed by St. HOPE Public Schools. Building on a century and a half of rich tradition and heritage, the mighty Dragons continue to proudly display the purple and white school colors and their unrivaled school spirit.

At Sac High, the motto is "Service for Others." Through community service, students develop a strong sense of civic responsibility while giving back to the community in which they live.

VISION

To create one of the finest urban high schools in America

MISSION

To graduate self-motivated, industrious and critically thinking leaders who are committed to serving others, passionate about lifelong learning and prepared to earn a degree from a four-year college.

MOTTO

Service for others

SCHOOL PRIDE

SCHOOL MASCOT:

Dragon

FIGHT SONG:

Fight Dragons fight
For the purple and the white
Sturdy and true
Today means victory for you
Our banners unfurled
For we're here to tell the world
We'll fight for Sacramento
So fight, mighty Dragons fight!

OFFICIAL SCHOOL COLORS:

Purple and White

SCHOOL HYMN:

In the sunshine of the valley,
Glorious to view,
Stands so proudly Sacramento
Alma mater true.
In the darkness of the battle, ever shining bri
Hail to thee O' Sacramento, purple
and the white.

SAC HIGH'S BIG GOALS FOR STUDENT ACHIEVEMENT

1. Every student achieves above 95% Attendance
2. Every student masters 80% of the course content (earns a minimum grade of a B- in all classes)
3. Every student is on track to fulfill the A-G requirements upon graduation
4. Every student completes 20 hours of community service per term (40 per year)
5. Every student earns 10 school pride points per term (20 per year)
6. Every student scores advanced or improves one performance level on the relevant exams for their grade level

SAC HIGH'S EXPECTED SCHOOL-WIDE LEARNING RESULTS (ESLRs)

1. Students will be industrious, critical thinkers demonstrated by their academic success in all content areas.
2. Students will be lifelong learners who are prepared to attend and be successful at a 4-year college.
3. Students will be knowledgeable and effective citizens who demonstrate leadership and interpersonal skills in diverse settings and are committed to serving others.

St. HOPE'S AND SAC HIGH'S 5 PILLARS

High Expectations. Sac High holds all students, families and staff to high standards for academic achievement and character development. There are no excuses for not meeting the expectations.

Choice and Commitment. Students, families and staff who choose to be a part of Sac High take responsibility for their learning and commit to putting in the time and effort required to achieve success.

More Time. There are no shortcuts. Sac High offers more time and support directed toward student learning.

Focus on Results. Sac High focuses relentlessly on high academic performance that enables students to succeed in college and the world beyond.

Power to Lead. The measure of a person's success is in what s/he gives to others. Through community service, students are empowered to become leaders and benefit the community in which they live.

ALL STUDENTS WILL STRIVE TO ACHIEVE OUR DRAGONS' VALUES

Discipline

Respect

Ambition

Grit

Optimism

Navigation

Service

COMMITMENT TO EXCELLENCE CONTRACT

TEACHER/STAFF COMMITMENT

We fully commit to our students and the broader Sacramento Charter High School Community in the following ways:

1. We will hold consistent, high expectations for all students, parents, and each other and foster a sense of pride, respect, and teamwork in our words, deeds, and actions.
2. We will make every effort to “be the constant, not the variable” in our students’ lives and we will model the expectations we strive for our students to meet or exceed.
3. We will embrace diversity and protect the interests and rights of all individuals, creating a safe and caring space for all of our students to learn.
4. We will help students, staff, faculty, parents, community members, and visitors feel welcome by focusing on excellent customer service and treating one another with kindness, courtesy, and respect.
5. We will meet and talk regularly with parents, providing them with updates on the progress of their child(ren) and make ourselves available to students and parents, and any concerns they might have.
6. We will always strive to be the best teachers we can be and do whatever it takes to prepare our students to excel in college and in life.
7. We will plan and collaborate with colleagues to design and implement the best classroom teaching experiences possible.
8. We commit to ongoing professional development and constant learning to ensure we continue to refine our craft and learn the best practices that will ensure all of our students learn at high levels.

I understand that failure to adhere to these commitments can lead to my removal from Sac High.

Teacher/staff member Signature: _____

COMMITMENT TO EXCELLENCE CONTRACT

PARENT(S)/GUARDIAN(S) COMMITMENT

We fully commit to our child and the broader Sac High community in the following ways:

1. I will help my child in the best way I know how to take no shortcuts in preparing for college and life. I will do whatever it takes to help him or her to learn.
2. I will partner with the teachers and staff to help my child excel in school, both academically and behaviorally.
3. I will make sure my child is ready to learn in class at Sac High every school day by 7:55 a.m. (or the appropriate start time) and I will make any necessary arrangements so that my child can dedicate time beyond the school day to learning, including after school, Saturdays and summer school.
4. I will make myself available to my child and the school as needed and I will do my best to attend at least one student led conference with my child and their advisor.
5. If my child is going to miss school, I will notify the school as soon as possible.
6. I will read carefully all the papers that the school sends home to me.
7. I will support school initiatives, activities, the staff and other parents.
8. I will make sure my child follows the Sac High uniform and dress code policy.
9. I understand that my child must follow the Sac High rules as explained in this student-parent handbook so as to protect the safety, interests, and rights of all individuals in the classroom. I understand that it is not the school but it is I and my child(ren) who are responsible for their behavior and actions.
10. I will help create a safe space for all Sac High families, students, and staff by respecting the school and the community.

I understand that failure to adhere to these commitments can cause my child to lose various Sac High privileges.

Parent(s)/Guardian(s) Signature: _____

COMMITMENT TO EXCELLENCE CONTRACT

STUDENT COMMITMENT

I fully commit to myself, my family, my teachers and the broader Sac High Community in the following ways:

1. I will give my best effort to be the best learner I can be. This means I will not take shortcuts. I will come to school every day prepared to learn and will work, think, and behave in the best way I know how.
2. I am responsible for my own behavior. If I make a mistake, this means I will tell the truth to my teachers, accept responsibility for my actions and find a solution moving forward.
3. I will always behave so as to protect the safety, interests, and rights of all individuals in the classroom. This also means that I will always listen to all Sac High staff and my teammates and give everyone my respect.
4. I will put forth my best effort toward my fellow students and my learning. I will take charge of my own learning by making sure I get help, asking questions in class or after class, and completing my homework.
5. I will take pride in our school by respecting the facility and helping keep it clean and striving to leave every place better than I found it.
6. I will treat my classmates, the staff, and visitors with kindness, courtesy, and respect.
7. I will be in my class prepared to learn at Sac High every day by 7:55 a.m. (or the appropriate start time) and, if necessary, I will dedicate time beyond the school day to learning, including after school, Saturdays, and summer school.
8. I will always make myself available to parents, teachers, and staff and will address any concerns they might have.
9. I will follow the Sac High uniform and dress code policy.
10. I will abide by the policies and regulations as explained in this student-parent handbook and I will be subject to disciplinary action should I not meet the expectations outlined therein.

I understand that failure to adhere to these commitments can cause me to lose various Sac High privileges and may lead to me returning to my home school.

Student Signature: _____

GOVERNANCE

St. HOPE Public Schools Committed to Student Achievement

St. HOPE, founded by Sacramento's current Mayor Kevin Johnson, began as an after school program in a portable classroom at Sac High in 1989. St. HOPE Public Schools, founded in 2002, is a non-profit public benefit 501c(3) corporation that provides students in urban communities with a quality public education. St. HOPE Public Schools includes Triumph Center for Early Childhood Education, PS7, serving grades K-8, Oak Park Prep a seventh and eighth grade middle school, and Sacramento Charter High School, a ninth through twelfth grade comprehensive, college prep high school comprised of seven small pathways.

St. HOPE Public Schools' BOARD OF DIRECTORS

Michelle Johnson, Chair
Tracy Stigler, Vice Chair
John Taylor, Secretary
Gladys Mitchell, Parent Representative
Kevin Nagle
Dorene Dominguez
John Finegan
George Fatheree, III
Dennis O'Reilly
Dr. Ron Tom
Shelby Mitchell, outgoing Student Board Member

St. HOPE Public Schools' Superintendent

Erik Swanson

Each school operated by St. HOPE Public Schools will be autonomous and led by a principal, who will be held accountable by the SHPS Superintendent and Board of Directors for complying with the policies and procedures established by both the SHPS Board of Directors and the school. The Principal has the authority or autonomy to manage the day-to-day operations, program of study, curriculum and instruction in a manner s/he chooses. Each school will be accountable for student learning and mastery of the California K-12 academic content standards which now include the Common Core State Standards (CCSS) and Next Generation Science Standards (NGSS). Principals will be responsible for working closely with their faculties to ensure the well-being of their respective schools, their staffs, and students.

School Site Council

Sac High encourages all groups to participate in and share responsibility for the educational process and educational results. In order to achieve this important end, the school convenes a School Site Council comprised of teachers, staff, administrators, parents, students, and community representatives. The California *Education Code* and the *No Child Left Behind Act of 2001* require the School Site Council's participation in certain school wide planning activities including the LEA's consolidated application and the Single Plan for Student Achievement. Bylaws have been developed to govern the School Site Council's composition and its policies and procedures. With the exception of the school's principal, all members of the School Site Council are voted onto the Council by a vote of their peers. Meeting dates, times, and agendas are regularly posted to the Sac High website in accordance with open meeting laws in the state of California.

PARENTAL INVOLVEMENT

Sac High recognizes the fact that schools cannot work in isolation from parents and families in educating youth. By working together, parents and Sac High educators can create an educational experience for each student that allows learning to continue at home and beyond the classroom walls. Research shows that:

- When parents are involved, students tend to achieve at higher levels in school, regardless of socioeconomic status, ethnic/racial background, or parents' education level.
- The more extensive the parent involvement, the higher the student achievement.
- When parents are involved in students' education, those students generally have higher grades and test scores, better attendance, and complete homework more consistently.
- Students whose parents are involved in their lives have higher graduation rates and greater enrollment rates in postsecondary education.

Parent involvement is identified as one of the most important determinants of student success. Sacramento Charter High School builds on its demonstrated success in working with parents and involving them with the school in a meaningful way. Communication with Sacramento Charter High School parents will be regularly accomplished through mail, e-mail, telephone, and parent meetings. Parents are encouraged to actively participate in their child's education through visiting classrooms, helping students develop personalized learning plans, attending meetings, and volunteering at school events, such as dances and sporting contests. In addition, it is expected that parents or guardians participate in at least one student led conference each year with their child and their child's advisory teacher.

With this in mind, Sac High and St. HOPE Public Schools have developed a written Parental Involvement Policy that is available to all parents. The policy outlines the importance of parental involvement at all levels of education, how information is disseminated to parents regarding the school's and their child's performance, and how parents can become involved in their children's education. The Parental Involvement Policy is available in the Sac High front office or may be printed from the Sac High website.

PARENT'S RIGHT TO KNOW

Release of Information to Institutions of Higher Education and Military Recruiters: Military recruiters and institutions of higher education may request student information, commonly referred to as 'directory information,' including such items as names, addresses, and telephone numbers and this information is generally not considered harmful or an invasion of privacy if disclosed. Parents have the right to request that the information not be disclosed without prior written consent. Parents not wanting information released can opt out by signing the form available at the school (per Family Educational Rights and Privacy Act, FERPA, and Elementary and Secondary Education Act, ESEA, 9528).

Teacher and paraprofessional qualifications: Parents have the right to request and receive certain information on the professional qualifications of their child's classroom teachers and paraprofessionals providing service to the child. The qualifications that may be disclosed are: if the teacher has met state qualifying and licensing criteria, state commission on teacher credentialing status, degree major(s) held by the teacher, and the qualifications of any paraprofessional servicing the child (per Elementary and Secondary Education Act, ESEA).

ALUMNI ORGANIZATIONS

Alumni Association: Sacramento Charter High School wants to build on its 160 years of rich heritage and traditions. Alumni participation is essential to this goal. The Alumni Association consists of all Sac High (Sacramento High for 1856-2003 and Sacramento Charter High School for 2004-2016) graduates and provides a base of support for the school through fundraising and the sharing of individual resources.

SACRAMENTO CHARTER HIGH SCHOOL 2016-17 CALENDAR AND KEY DATES

August 10	First day of school, Term 1 Begins
August 25	Back to School Night, 6 p.m.
September 9	1 st Quarter Ends for Term 1, official grade checks
<i>September 2</i>	<i>No school for students</i>
<i>September 5</i>	<i>Labor Day</i>
October 4-5	Midterms (early release days)
October 5	1 st Semester Ends for Term 1, official grade checks
<i>October 6-17</i>	<i>Fall Break</i>
<i>November 11</i>	<i>Veterans Day</i>
November 18	3 rd Quarter Ends for Term 1, official grade checks
<i>November 21 - 25</i>	<i>Thanksgiving Holidays</i>
December 20-21	Term 1 Finals
December 21	2 nd Semester Ends for Term 1, official grade checks and final grades for transcripts
<i>Dec 22-Jan 10</i>	<i>Winter Break</i>
January 11	Term 2 Begins
<i>January 23</i>	<i>Dr. Martin Luther King, Jr. Day</i>
January 26	Open House, 6 p.m.
February 17	1 st Quarter Ends for Term 2, official grade checks
<i>February 20</i>	<i>President's Day</i>
March 21-22	Midterms
March 22	1 st Semester Ends for Term 2, official grade checks
<i>March 27-31</i>	<i>Spring Break</i>
<i>April 28</i>	<i>No school - non-student day</i>
May (1 st two weeks)	AP Exams on assigned days by subject, dates set by College Board
May 5	3 rd Quarter Ends for Term 2, official grade checks
May 29	<i>Memorial Day</i>
June 8-9	Term 2 Finals
June 9	2 nd Semester Ends for Term 2, final grades for transcript
June 10	Class of 2017 Graduation 12pm at the Memorial Auditorium

Sacramento High School
2016-17 196 Day Calendar



Sacramento High School Main Office
2315 34th Street, Sacramento, CA 95817
Phone: (916) 277-0200
Fax: (916) 277-0370

Sacramento High School Administration

Superintendent Erik Swanson
Principal Dr. Michelle Seijas
Assistant Principal Patrick Durant
Assistant Principal Jerad Hylen

Key Dates / Observed Holidays

July 25th to July 29th New Teacher Orientation Training
July 28th to Aug 8th Returning / All Staff Professional Development
August 8th St. HOPE Leadership Institute
August 10th First day of school
September 3rd Professional Development
September 5th Labor Day
October 6th & 7th Professional Development
October 10th to 14th Fall Intercession
October 17th Professional Development
November 11th Veterans Day
November 21st to 25th Thanksgiving Break
December 22nd Professional Development
Dec 23rd to Jan 6th Winter Break
January 9th & 10th Professional Development
January 23rd Martin Luther King Jr. Day
February 20th Presidents Day
March 23rd & 24th Professional Development
March 27th to 31st Spring Break
April 3rd Professional Development
April 28th Professional Development
May 28th Memorial Day
June 9th Last Day of Classes
June 10th Professional Development / Final Day

Summary of Work Days

175 School Days
39 Quarter 1 Days - Ending 10/5
41 Quarter 2 Days - Ending 12/21
49 Quarter 3 Days - Ending 3/22
46 Quarter 4 Days - Ending 6/8
21 Professional Development Days
3 New Teacher Orientation Days

2016

July

Su	M	T	W	Th	F	S
					1	2
3	4	5	6	7	8	9
10	11	12	13	14	15	16
17	18	19	20	21	22	23
24	25	26	27	28	29	30
31						0

August

Su	M	T	W	Th	F	S
	1	2	3	4	5	6
7	8	9	10	11	12	13
14	15	16	17	18	19	20
21	22	23	24	25	26	27
28	29	30	31			
						16

September

Su	M	T	W	Th	F	S
					1	2
3	4	5	6	7	8	9
10	11	12	13	14	15	16
17	18	19	20	21	22	23
24	25	26	27	28	29	30
						20

October

Su	M	T	W	Th	F	S
					1	
2	3	4	5	6	7	8
9	10	11	12	13	14	15
16	17	18	19	20	21	22
23	24	25	26	27	28	29
30	31					13

November

Su	M	T	W	Th	F	S
	1	2	3	4	5	
6	7	8	9	10	11	12
13	14	15	16	17	18	19
20	21	22	23	24	25	26
27	28	29	30			
						16

December

Su	M	T	W	Th	F	S
					1	2
3	4	5	6	7	8	9
10	11	12	13	14	15	16
17	18	19	20	21	22	23
24	25	26	27	28	29	30
						31
						15

2017

January

Su	M	T	W	Th	F	S
1	2	3	4	5	6	7
8	9	10	11	12	13	14
15	16	17	18	19	20	21
22	23	24	25	26	27	28
29	30	31				
						14

February

Su	M	T	W	Th	F	S
	1	2	3	4		
5	6	7	8	9	10	11
12	13	14	15	16	17	18
19	20	21	22	23	24	25
26	27	28				
						19

March

Su	M	T	W	Th	F	S
					1	2
3	4	5	6	7	8	9
10	11	12	13	14	15	16
17	18	19	20	21	22	23
24	25	26	27	28	29	30
						31
						16

April

Su	M	T	W	Th	F	S
					1	
2	3	4	5	6	7	8
9	10	11	12	13	14	15
16	17	18	19	20	21	22
23	24	25	26	27	28	29
30						18

May

Su	M	T	W	Th	F	S
	1	2	3	4	5	6
7	8	9	10	11	12	13
14	15	16	17	18	19	20
21	22	23	24	25	26	27
28	29	30				
						21

June

Su	M	T	W	Th	F	S
					1	2
3	4	5	6	7	8	9
10	11	12	13	14	15	16
17	18	19	20	21	22	23
24	25	26	27	28	29	30
						7

SACRAMENTO HIGH SCHOOL 2016-2017 BELL SCHEDULE

"Service for Others"
2315 34th Street, Sacramento, CA 95817
(916) 277-6200

First lunch schedule

Second lunch schedule

Regular Schedule

Period 1 7:55 – 9:10
Advisory 9:15 – 9:45
Period 2 9:50 – 11:05
Lunch 11:05 – 11:35
Period 3 11:40 – 12:55
Period 4 1:00 – 2:15
Period 5 2:20 – 3:35

Period 1 7:55 – 9:10
Advisory 9:15 – 9:45
Period 2 9:50 – 11:05
Period 3 11:10 – 12:25
Lunch 12:25 – 12:55
Period 4 1:00 – 2:15
Period 5 2:20 – 3:35

Research & Development Schedule – Early Release Every Wednesday

Period 1 7:55 – 8:50
Advisory 8:55 – 9:25
Period 2 9:30 – 10:25
Lunch 10:25 – 10:55
Period 3 11:00 – 11:55
Period 4 12:00 – 12:55
Period 5 1:00 – 1:55

Period 1 7:55 – 8:50
Advisory 8:55 – 9:25
Period 2 9:30 – 10:25
Period 3 10:30 – 11:25
Lunch 11:25 – 11:55
Period 4 12:00 – 12:55
Period 5 1:00 – 1:55

Minimum Day Schedule

Midterms and Finals Schedule

**Dates: 9/23, 11/18, 1/27, 2/10, 2/24,
3/10, 4/21, 5/19**

Period 1 7:55 – 8:50
Period 2 8:55 – 9:50
Period 3 9:55 – 10:50
Period 4 10:55 – 11:50
Period 5 11:55 – 12:50

Day 1: 10/4, 12/20, 3/21, 6/8

Period 1 7:55 – 9:25
Period 2 9:35 – 11:05
Period 3 11:15 – 12:45

Day 2: 10/5, 12/21, 3/22, 6/9

Period 4 7:55 – 9:25
Period 5 9:35 – 11:05

ACADEMIC PROGRAM COURSES OF STUDY

Core Curricular Subjects

Sacramento Charter High School offers History-Social Science, English Language Arts, Mathematics, Science, Physical Education and Foreign Language as core subjects. Instruction in all core curricular subjects will be aligned with the state's appropriate standards and will reinforce Sac High's vision, mission, values, and expectations. For a complete listing of core course offerings and descriptions please see the Sacramento Charter High School 2015-16 Course Catalog.

History-Social Science: At Sac High students will receive a college preparatory education in the social sciences. Each strand will focus on civic and economic implications using research and analysis.

A thorough understanding of history is necessary for students to become active citizens in our country, and, with growing interconnectedness, our world. The History-Social Science curriculum will prepare students with knowledge of major events of history, teach them to analyze the effect of the past on the present, and provide them with the skills necessary to evaluate current events, political structures, and philosophies.

The History-Social Science curriculum will be reading intensive and will involve the analysis of primary and secondary sources. The social science curriculum for most, but not all students, begins with a ninth grade World Geography class. This course allows students to analyze geographical regions of the world and develop fundamental social studies skills including mapping, data analysis and cultural study. Students build on this knowledge/skill set as they master World History in their sophomore year. In junior year, all students complete the high school US History requirement. As an upper division course, US History goes beyond listing dates and events to the analysis and evaluation of the factors that have shaped the United States over time. Seniors take Government and Economics as a culminating course. These topics provide an in depth study of government structures and economic models across many different societies. All history classes require written essays and reports, many of which must be typed. Students will be held accountable not only for content, but also for style, organization, and mechanics.

English-Language Arts: Our English-Language Arts program provides a challenging and rewarding curriculum that balances literary and expository texts that are culturally diverse and intellectually stimulating. We place the utmost priority on developing reading and writing skills. To this end, the English-Language Arts program is comprised of a hybrid of Common Core State Standards-aligned Springboard curriculum and the California State University's Expository Reading and Writing Courses. Students will work collaboratively to guide each other's understanding of texts, novels, media and other sources as they complete, at minimum, four full years of English Language Arts course.

Mathematics: The mathematics curriculum at Sacramento Charter High School provides our students with the knowledge and skills they need to succeed at competitive four-year colleges and universities. We recognize students will enter Sacramento Charter High School prepared for different levels of math. To meet this need, we provide appropriate support and course offerings to ensure students will be successful in high school level math. In order to have enough time for students to catch up to and then master high school and college level math, we use the following strategies:

- **Four years of math:** all students take four (4) full years of math, which must include Algebra I/Math I, Geometry, Algebra 2, and may also include Numeracy, Trigonometry, EAP math, Pre-Calculus, and AP Calculus.
- **Interventions:** When a student is below grade level or unable to complete the work in their assigned class we have a number of strategic interventions that we implement including, but not limited to:
 - Assignment into an supported section of their math course
 - Opportunities after school to work with teachers, tutors, other staff and peers
 - One on one tutoring
 - Summer school
- **Focus on mastery:** Success in math relies on a strong foundation of skills that build cumulatively over time. Through frequent assessments we perform mastery checks to ensure that students are learning the standards we are teaching. If students are not demonstrating mastery of a skill (or set of skills), we can quickly respond to that need with re-teaching and support.

Physical Education: All students at Sacramento Charter High School are required to complete two terms of Physical Education in order to graduate. All freshmen students take Freshman PE 1 and Freshman PE 2 where the major emphasis will be on the understanding and development of personal fitness, and where students will be expected to participate in a variety of team, dual, and individual sports. Advanced PE and Weight Training courses are also available to upper classmen as elective courses and select freshman may be invited to participate.

Science: At Sac High, the science curriculum will place heavy emphasis on learning the knowledge, processes, and skills that students need in order to understand the scientific method and its implications. These processes (e.g. observing, sequencing, measuring, classifying, describing, experimenting, inferring, predicting, evaluating, synthesizing) are valuable skills to reinforce across disciplines and will be learned through experimentation and investigation, which will then require written elements, such as lab write-ups and reports.

In addition to learning the processes of science, students will learn valuable content in the areas of Biology (human, animal, and plant), Chemistry and Physics. Each science class will include not only scientific content, but it will also provide an interdisciplinary bridge between math, science, English-Language Arts, and technology, as well as a history of science component.

Foreign Language: Our world is a global community whose citizens should view it as one that reaches beyond their national borders. For this reason, the study of foreign languages and cultures is vital to the education of all students.

The goal of studying a foreign language is to allow meaningful and practical communication. While expanding their academic and intellectual experiences, students will also discover the joy of communicating in another language and enhance their self-worth and academic achievement. At Sacramento Charter High School, foreign language is taught in context, using a methodology known as Teaching Proficiency through Reading and Storytelling (TPRS). TPRS is a powerful tool that equips students to communicate confidently at an advanced level in a short amount of time.

Career Theme Pathways: In addition to our core curricular courses, Sac High's career pathways model offers students the opportunity to focus their elective areas of study in a meaningful way. Each pathway offers a sequence of courses that fully develop a student's knowledge and experience within their primary area of interest. At the end of their freshman year, students are asked to select an area of focus that will guide their elective education for their remaining three years of study. Each pathway has a unique scope and sequence designed to fully and meaningfully develop a student's knowledge and experience within a particular field, culminating in a senior capstone course where they will complete a senior project composed of work completed within their focus area. There are multiple elective courses, internship opportunities, clubs and activities aligned to each pathway. We believe that in choosing a pathway at the end of their 9th grade year, students have a more meaningful academic experience, which bolsters their interest in a particular subject area or career path, and demonstrates to colleges and universities that they have a comprehensive elective education within a particular area. There are seven different pathways and they are: Art, Business, Engineering, Health Sciences, Law & Public Service, Photography, and Visual Communications.

For a complete listing of all course offerings and descriptions, including our pathways and the courses within each, please see the Sacramento Charter High School 2015-16 Course Catalog.

Examinations

Scholastic Assessment Test (SAT) / American College Testing Program (ACT): The University of California and California State University systems require that all students take the SAT and/or ACT in order to be eligible for admission. Sac High expects that all students take the SAT and/or ACT at least once prior to graduation.

SAT Subject Test (SAT II): These are content-based tests that allow you to showcase your achievement in specific subject areas where you excel. Some colleges also use Subject Tests to place students into the appropriate courses. Based on your performance on these test(s), you could potentially fulfill basic requirements or receive credit for introductory-level courses.

Advanced Placement Tests (AP): All students enrolled in Advanced Placement courses are expected to take the AP test associated with the course at the end of the year. Students who do not take the AP exam for a given course will forfeit the AP designation on their transcript and will not receive the additional grade point associated with AP course completion. Furthermore, college credit will only be awarded for students who take and pass the AP exam. All colleges currently accept a score of 4 or 5 and some accept a score of 3. A score of 3 or higher is considered passing.

GRADUATION REQUIREMENTS

St. HOPE Public Schools and Sac High expect all graduates of Sacramento Charter High School will complete the coursework required to attend a school within the University of California (UC) or California State University (CSU) system upon their high school graduation. Sac High is determined to ensure all of its students are on track to being eligible for UC or CSU admission. As such, Sac High has aligned the school's graduation requirements to meet or exceed the A-G requirements necessary for students to be eligible for UC and/or CSU admission.

Course / Credit Requirements:

SACRAMENTO CHARTER HIGH SCHOOL GRADUATION REQUIREMENTS		
UC/CSU A-G REQUIREMENT, reference only (Terms required)	COURSES NEEDED TO MEET THE GRADUATION REQUIREMENTS AT SAC HIGH	SAC HIGH CREDITS REQUIRED (Terms)
A. History / Social Science (2 terms)	World History/ U.S. History / American Government and Economics	30 (3)
B. English (4 terms)	English 9 / 10 / 11 / 12 (Advanced ELD may satisfy <u>one</u> English course requirement)	40 (4)
C. Mathematics (3 terms required / 4 terms recommended)	Algebra 1 / Geometry / Algebra 2 (Pre-Calculus would be required as a third year of math if a student takes Geometry in 9 th grade)	30 (3) *Note that Sac High students will all have 4 years of math
D. Laboratory Science (2 terms required / 3 terms recommended)	1 Life Science (Biology or Anatomy) and 1 Physical Science (Chemistry or Physics)	20 (2) (10 Life Science; 10 Physical Science)
E. Language Other Than English (2 terms same language required; 3 terms recommended)	Spanish 1 and 2, Spanish 2 and 3, <u>or</u> Spanish for Spanish Speakers 1 and 2	20 (2) (Same language)
F. Visual and Performing Arts (1 term)	Visual Art	10 (1)
G. College Preparatory Electives (1 term)	1 advanced courses in the following college-preparatory elective areas: Social Science, English, Mathematics, Laboratory Science, Language other than English, Art	10 (1)
Additional Required Courses	Physical Education	20 (2)
	Additional Elective Courses (Either courses required by student's small school strand or college-preparatory electives)	60 (6)
	Advisory	20 (8) *Each term of advisory is 2.5 credits
Total Credits Required:		260

As a college prep high school, Sac High believes that in order for students to be prepared to graduate from a 4-year college, it is necessary for students to maintain a rigorous and comprehensive schedule through all four years of high school. By following our third pillar of "More Time," all students will take four years of Mathematics and four years of English.

ACADEMIC POLICIES

Sacramento Charter High School is a school of choice, of excellence and of high expectations. Sac High expects all students will graduate from high school having completed an A-G college-preparatory curriculum necessary for admission to the University of California ("UC") and/or California State University ("CSU") systems. Recognizing that UC/CSU systems only accept credit for courses where students earn a 70% or better and in keeping with our first pillar of high expectations, Sac High requires students to earn at least 70% in order to get credit for a course.

Only a student's term grades (final grade in December and at the end of the school year) shall become a part of his or her permanent record. Point values are assigned to each letter grade; these point values are used in the determination of the grade point average (GPA).

Weighting of Grades: Grades for students enrolled in Advanced Placement ("AP") classes are weighted to reflect the greater challenges involved in these courses. In an AP class, 1.0 is added to the point value of the letter grade received (e.g., a "B" in an AP class has a point value of 4.0 rather than a 3.0.). Both GPAs will be listed on the student's transcript. PLEASE NOTE: Most colleges and universities recalculate GPAs and many do not weight grades for the purposes of GPAs. However, colleges and universities may weigh the value of the more challenging AP and Honors course work when determining the rigor of a student's course of study when considering their application for admission.

Grades and Grade Point Value: Grades shall be awarded as follows and shall have the following point value (final grades are rounded to the nearest percent):

Letter Grade	Percentage	Point Value for GPA Calculation
A	94 – 100%	4.0
A-	90 – 93%	3.7
B+	87 – 89%	3.3

B	84 – 86%	3.0
B-	80 – 83%	2.7
C+	77 – 79%	2.3
C	70 – 76%	2.0
NCR (No Credit Received)	0 – 69%	0.0

Advisory as a Credit / No Credit Courses: The advisory class is mandatory for all students for all four years (eight total terms) and is graded based on credit or no credit. A student must receive an 80% grade of “CR” (Credit) in advisory to accumulate credits towards graduation*. A “NC” (No Credit) grade in advisory class will result in the student earning 0 credits towards graduation for that specific term of advisory. The student is then required to complete an additional 25 community service hours for every term in which a grade of NC was received (note that community service hours cannot be double counted towards both the 20 hours for the current term and the 25 makeup hours for past terms).

*Please note that in Sac High’s student information system, Illuminate, the advisory grade will be listed as “CR” to indicate a student is receiving credit or as “NC” to indicate a student is receiving no credit. However, on a student’s official transcript the advisory grade will be listed as a “C” to indicate credit earned. “NC” will still be used to indicate no credit.

Academic Recognition: Sacramento Charter High School believes in recognizing and rewarding those who meet and exceed expectations. These acknowledgements are made on an informal basis daily and weekly for both academic achievement and for upholding the school’s values. Formal acknowledgements are made at the end of each semester with the following honor roll announcements and awards:

Cum Laude	Magna Cum Laude	Summa Cum Laude
GPA of Un-weighted 3.00 to 3.39	Un-weighted GPA of 3.40 to 3.79	Un-weighted GPA of 3.80 or higher

In addition to the honor roll recognitions listed above, Sacramento Charter High School acknowledges students who exemplify the school’s expectations, values and spirit through various opportunities spread throughout the year. Sac High aims to recognize and celebrate students who embody what it means to be a dragon, through academic achievement, excellent attendance and upstanding citizenship. Formal acknowledgement is made at the end of each semester with the following levels of status students may earn, each of which results in various privileges:

Status	Required GPA	Attendance Requirement	Behavioral Requirement
Platinum	Summa Cum Laude: 3.8 or higher	95% attendance	Zero referrals, zero suspensions
Gold	Magna Cum Laude : 3.4-3.79	95% attendance	3 or fewer referrals, zero suspensions
Silver	Cum Laude 3.00-3.39	95% attendance	3 or fewer referrals, zero suspensions
High-5	Improve GPA by .5 from one semester to next semester (i.e. from 2.0 to 2.5)	95% attendance	5 or fewer referrals, zero suspension

Grading Period & Progress Report Calendar:

Term 1, Quarter 1	Begins	August 10
5 Weeks	Ends	September 9
	Progress reports run for grade checks for athletics and activities	September 13
	First day students are ineligible for athletics and activities	September 14
Term 1, Quarter 2	Begins	September 12
5 Weeks	Ends (end of Term 1, Semester 1)	October 5
	Progress reports run for grade checks for athletics and activities	October 11
	First day students are ineligible for athletics and activities	October 12
Term 1, Quarter 3	Begins	October 18
4 Weeks	Ends	November 18

	Progress reports run for grade checks for athletics and activities	November 22
	First day students are ineligible for athletics and activities	November 23
Term 1, Quarter 4	Begins	November 28
4 Weeks	Ends (end of Term 1, Semester 2)	December 21
	Progress reports run for grade checks for athletics and activities	December 27
	First day students are ineligible for athletics and activities	December 28
	Transcripts posted	January 11
Term 2, Quarter 1	Begins	January 11
6 Weeks	Ends	February 17
	Progress reports run for grade checks for athletics and activities	February 21
	First day students are ineligible for athletics and activities	February 22
Term 2, Quarter 2	Begins	February 21
6 Weeks	Ends (end of Term 2, Semester 1)	March 22
	Progress reports run for grade checks for athletics and activities	March 28
	First day students are ineligible for athletics and activities	March 29
Term 2, Quarter 3	Begins	April 4
4 Weeks	Ends	May 5
	Progress reports run for grade checks for athletics and activities	May 9
	First day students are ineligible for athletics and activities, including senior activities	May 10
Term 2, Quarter 4	Begins	May 8
4 Weeks	Ends (end of Term 2, Semester 2)	June 8
	Progress reports run for grade checks for athletics and activities	June 13
	Transcripts posted	June 16

Eligibility requirements for Athletics & Activities

Please note that all final grades are rounded to the nearest percent. At the official grade check deadlines and dates listed above, a student must meet the following criteria to be eligible for athletics (pg. 25) and/or specified activities (pg. 23):

- Earn a 2.0 overall GPA
- Earn a score of 80%/"CR" for credit advisory (will be listed as a "C" for credit on student's transcript)
- Have no more than one NCR (no credit) in their current classes. NCRs result from an overall grade below 70%. An NCR will result from an overall grade below 80%.

Academic Ethics: The highest level of respect must characterize the relationship between the teacher and the student. When a teacher gives any assignment - homework, paper, project, lab, etc. - or when a quiz or exam is given, that teacher is building the framework for the student's learning. When the student returns the assignment or takes the quiz or exam, his or her name at the top of the paper indicates that s/he has followed the teacher's directions and has not taken credit for any work that is not his or her own. When a student uses the work of another it is called cheating. Please note the following guidelines and follow them carefully in your work at Sacramento Charter High School.

To be in compliance with the academic ethics guidelines students must adhere to the following:

1. Students will not use or give to other students any notes, materials, or other sources of information on any assignment including homework, quizzes, tests, or semester examinations that have not been approved by the teacher.
2. Students' homework and in-class work fulfill the intention of the instructor and assignment in a specific class.
 - a) Individual assignments must be represented by individual work.
 - b) Group assignments must be represented by group work.
 - c) In no case is direct copying allowed.
3. Students will not plagiarize in any form. Plagiarism presents the work or ideas of another as one's own. This includes:

- a) Direct copying of another person's (living or dead) work.
 - b) Using any amount of another person's material or ideas without proper documentation.
 - c) Paraphrasing another person's original material without proper documentation.
4. Students will not publish information regarding exams or falsify information regarding assigned grades.

Academic Dishonesty: Students who do not meet the standards of academic ethics outlined above will be reported by the teacher or appropriate staff to the principal or their designee. The student will receive a grade of zero on the test, quiz, or assignment. On the first occasion, appropriate disciplinary action will be taken and the school will contact the parents. A student caught violating academic ethics for a second time may be suspended and is subject to the school's suspension and expulsion policy. Any act of academic dishonesty may impact the student's participation in student athletics and activities up to and including commencement (graduation).

STUDENT SERVICES

COUNSELING AND GUIDANCE

One of the most critical components of our educational model is the personalization of the schooling experience for our students. Excellent schools serve as positive learning environments and also as a place where young people can build meaningful relationships with adult role models. At Sac High we've completely re-envisioned and re-engineered an approach to counseling.

While a traditional model of counseling has students seeing their counselors 2-3 times a year at most, Sac High's model essentially means our students have a much lower student to counselor ratio, and they are spending approximately 2 hours per week with their counselors (advisors) within this small group setting. We believe that our model provides students with an intensive counseling experience and ensures that all students are "known" in the school and have an advocate on campus.

Advisory: The advisory period serves as the primary counseling vehicle for students as well as the advisor taking on the role of chief advocate on campus for their advisees (students in their advisories). Sac High sets advisor to student ratio as low as possible across the campus to ensure students and their families can build close relationships with advisors while also maintaining the priority of every child having a high quality advisor. Sac High takes advisory seriously and, therefore, provides credit for advisory – credits that must be earned for students to graduate. In order to successfully pass advisory students are responsible for fulfilling the below specific requirements.

- Complete, track, and verify 20 hours of community service per term (40 per year)
- Earn, track, and verify 10 pride points a term (20 per year)
- Earn a "CR" for credit for advisory every term (two terms in a school year, eight terms over four years). Note that a "C" will be used on official student transcripts to indicate that credit has been earned.

Failure to complete any of the above three requirements in a term with at least an 80% results in an overall grade of "NC" for no credit and can only be changed with submission of 25 additional hours of approved community service. Students must earn credit for advisory for every term they are enrolled at Sac High in order to graduate. In addition, students must complete a student led conference (SLC) with their advisor and an involved adult annually.

Advisors are responsible for:

- Executing effective advisory lessons.
- Participating in grade level and whole school meetings to discuss and plan for advisory.
- Ensuring that students have completed Individualized Learning Plans in consultation with appropriate staff.
- Consulting with the counselors, ensuring that students have a rigorous and relevant course schedule set for each term and semester.
- Meeting with parents at minimum of once a year per student to participate in Student Lead Conferences (SLCs) where the student and parent(s)/guardian(s) will discuss the student's progress towards preparing for college.
- Communicating regularly with advisees' (students') teachers to understand the strengths, challenges and needs of their students.
- Handing out grade reports each week for advisees, to be returned the following school day, signed by parents.
- Contacting home regularly to praise students for work well done, follow up on any issues and concerns around attendance and school work and ensure alignment between home and school.

- Helping their advisees track community service hours and pride points.

Academic Intervention Conferences: Student led conferences are held formally during the school year for all students. In addition, for any student earning two or more NCRs a separate academic intervention conference will be held. The meeting will be facilitated by the student's advisor or designee and Parents/Guardians will meet with their child's teachers to discuss progress for the current year and, if needed, possible courses of action to improve performance. Parents are encouraged to contact any teacher and their child's advisor at any time during the course of the year to discuss problem areas.

Counseling: In addition to our advisors who serve students in these small group dynamics, we also have counselors whose main responsibilities are to:

- Work with students, families and advisors to develop appropriate course schedules for each student
- Collaborate with classroom teachers to assign academic interventions when necessary
- Create templates for Individualized Learning Plans (ILPs)
- Provide mental health counseling, in individual and group settings, and referrals to outside agencies as needed
- Facilitate partnerships with outside agencies on mental health issues and program development on campus
- Work with the registrar to ensure accurate student transcripts
- Ensure that ELD and SPED students are appropriately assigned to services and work with coordinators to communicate with teachers and staff about these students' needs
- Provide general information to students and advisors about course selection, A-G, graduation requirements, and student support services
- Manage interns from local colleges and universities to help with guidance and counseling responsibilities.

College Counseling: We provide our students with strong guidance in regard to the college application process. Our goal is to have all seniors apply and be accepted into a four-year college. The support that we provide students primarily sits with their senior advisor. We have developed an in depth curriculum which walks students through college admissions process and of a senior portfolio to house a student's resume, collection of references and recommendation, etc... During senior advisory students are exposed to and complete:

- College research
- College applications and essays
- All financial aid documentation and scholarship applications necessary for institutions of higher education

In addition to the comprehensive services provided by the advisors, we also have a college counselor who is responsible for:

- Owning the relationships with all of the colleges and universities across the country
- Distributing materials about college, standardized tests (ACT, SAT, etc...) and the college application process
- Arranging for college admissions officers to visit the Sac High campus
- Ensuring our students are exposed to colleges and universities across the country through a variety of venues
- Working closely with the senior advisors on the development and implementation of the 12th grade advisory curriculum

We strongly believe that this network of resources can provide our students with the one on one attention and support they need to successfully navigate through their high school career and build a strong foundation for college success, career and leadership in their community.

ACADEMIC SUPPORT

Sacramento Charter High School holds all students to high standards and is committed to providing assistance to all students who are not meeting our high academic expectations. Additional learning opportunities are available for students in need; these include tutoring during teacher's scheduled office hours, Dragon Academy, the after-school program, accelerated classes, and summer sessions. Services for students with special needs and English learners are also available.

In order to ensure that all students are successful, Sac High has implemented an Academic Intervention Conference (AIC) process. The AIC is a collaborative team of all pertinent staff, parents, and service providers of a student who meet to develop a systematic approach to ensuring success for the student. The focus is on the whole child, including behavior, academic, health, and social issues. The purpose is to find success for the student.

Special Education: Students with existing Individualized Education Programs (IEPs) are identified immediately upon enrollment. Students without an IEP may also be assessed for Special Education services after enrolling at Sac High. The IEP

team works together to ensure that each student receives special education services as specified in their IEP. The mission of the special education team is as follows:

“SHPS Special Education Team, in partnership with students, families, and the community through relentless and purposeful commitment to high expectations, strives to serve all students in the general education environment, increasing academic and social success, closing the achievement gap, and preparing all students for college.”

English Language Development Program (ELD): St. HOPE Public Schools is committed to effective educational program options for English Learners (ELs) that meet State and Federal standards for the prompt development of English language proficiency, and to give ELs an equal opportunity for mastery of a challenging core curriculum as efficiently as possible.

St. HOPE’s program for ELs is designed to enable ELs to acquire English and learn grade-level academic content. Students are expected to master the ELD standards and develop skills so they can also master state standards in their core classes.

Free & Reduced Meal Program: Free and reduced applications are available online and located in the Main Office. Students need to return the fully completed form with their Parent/Guardian’s signature or complete the process online if that service is available. The application may take several days to process. Please return signed paper applications to the Main Office. Once eligibility is established, students will receive the adjusted lunch price (Free or Reduced) when they get their meal.

STUDENT RECORDS AND RIGHTS

The Family Education Rights and Privacy Act (FERPA) is a federal law that protects the privacy of student education records. The law affords parents and students 18 years of age and over certain rights with respect to student records. Due to the strict guideline of FERPA, once the student reaches the age of 18 years old, rights transfer to the student. For students age 18 or older, the school can not disclose or release non-directory information such as the following information listed below, to anyone, including parents of the student, without the prior written consent of the student except to the extent that FERPA authorizes disclosures without consent.

- Social security numbers;
- Student identification number;
- Race, ethnicity, and/or nationality;
- Gender
- Transcripts; grade reports

FERPA, however, allows schools to disclose those records, without consent, and SHPS may do so, to the following parties or under the following conditions:

- School officials with legitimate educational interest;
- Other schools to which a student is transferring;
- Specified officials for audit or evaluation purposes;
- Appropriate parties in connection with financial aid to a student;
- Organizations conducting certain studies for, or on behalf of, the school;
- Accrediting organizations;
- To comply with a judicial order or lawfully issued subpoena;
- Appropriate officials in cases of health and safety emergencies; and
- State and local authorities, within a juvenile justice system, pursuant to specific State law.

Educational Records

FERPA gives parents/students the following rights regarding educational records:

1. These rights include access/inspection/review of records,
2. The right to request the amendment of student records that the parent or eligible student believes to be inaccurate,
3. The right to consent to disclosure of personally identifiable information contained in the student’s education records except to the extent that FERPA authorizes disclosures without consent and
4. The right to file complaints against the school for disclosing educational records in violation of FERPA.

Access to Student Record and Transcripts for current students: All request for student records such as, but not limited to, transcripts, attendance, discipline records, must be in writing. Students, parent/guardian must complete a request for transcripts/student records form before request is processed and released. All requests will be process within 2 business days.

Records will be forwarded to another district or school in which the child enrolls when requests are received by a student's new school of attendance. Request for student information by individuals or organizations listed below will be forwarded without written consent from student or parent where FERPA authorizes disclosures without consent:

1. School district personnel with legitimate educational interests
2. Specified federal and state educational administrators
3. Law enforcement or other public safety agencies with lawful access

Parents have the right to file a complaint with the U.S. Department of Education concerning alleged failures of the school district to comply with the Family Education Rights and Privacy Act. Send inquiries to:

Family Policy Compliance Office
U.S. Department of Education
400 Maryland Avenue
NW, Washington, D.C. 20202-5901

WITHDRAWAL POLICIES AND PROCEDURES

1. Parents/Guardians are asked to notify the school at least 48 hours in advance before withdrawing their student from school by taking the steps below:
 - a. Call the Sac High Registrar at 916-649-7928 or the main office at 916-277-6200.
 - b. Parent/Guardian must come to the school in person with a valid photo ID to inform of the withdrawal.
 - c. Student will not be issued any credit should they withdraw before the end of the semester (see pg. 11 for semester start and end dates).
2. Parent/Guardian must sign withdrawal paperwork at Sacramento Charter High School.
3. Prior to the withdrawal:
 - a. Student must return books that were checked out in his/her name or pay for any lost or damaged books
 - b. If student played sports, must return uniform or pay for lost or damage uniform.
 - c. Clear any outstanding fines/debts.
4. Once the student is clear of any textbooks and or fines, the school will release official transcripts.

STUDENT LIFE

STUDENT ACTIVITIES

Sac High is a vibrant, active campus teeming with students who are striving to always be “on the go” and walking with a sense of purpose and pride. There is no wasted time, no idle bodies as we work to prepare our students for college and life beyond. Our students understand that they must utilize every moment of their days productively engaged in academics or worthy extra-curricular activities. We aim for Sac High students to be well-rounded and excellent candidates for the most competitive colleges and universities across the country. Therefore, we have specific requirements for students to meet to earn the privilege of engaging in a variety of extra-curricular activities throughout their four years at Sac High.

Community Service: The Sac High school motto is “Service for Others” because we believe strongly in the need for students and all of us to be actively engaged in serving our community. Today’s youth are often disengaged and unaware of the world around them. Specifically, many lack knowledge of the social circumstances that lead to a dynamic of the “haves” and the “have not’s”. We seek to educate a cadre of young leaders who not only strongly understand these relationships but who are actively and aggressively seeking social change. Our students will develop a strong understanding of the issues of social justice that pervade society today and are oriented toward doing something about them. They care about and deeply understand the inequities that exist and how they can be changed by activism.

Armed with this orientation, we believe our students can be powerful change agents in the community and we require them to engage in service that will improve their community and the lives of others. We aim to teach students that they have an obligation to make things better for those who come after them. To that end, all Sac High students are required to complete 20 hours of community service hours per term (40 each year), for a total of 160 hours over the course of their four year tenure at the school. Students who transfer to Sac High after the fall term of 9th grade will be required to complete 20 hours of community service for every term of attendance at Sac High. Completed community service hours are submitted by students to and tracked by a student’s advisor.

It is the responsibility of each student to complete the required community service and turn in the appropriate documentation to their advisor before the assigned deadline at the end of each term. If 20 hours of service is not completed before the end of the term a student will automatically fail advisory and receive a grade of NC for no credit. Students must complete 25 hours of community service on top of the required hours in order to make up a grade of NC in advisory. Students must earn full credit by making up all NCs in advisory before graduating from Sac High. If a student is in need of ideas or resources for how to complete community service, they should contact their advisor or the Sac High front office.

Pride Points: We encourage our students to be active participants in building our Sac High Community. We aim to offer extracurricular opportunities for all students; students are encouraged to join a team, participate in a club, or to attend school-sponsored events throughout the year. By participating in school activities, students earn pride points and as part of their Advisory grade, students must earn 10 pride points per term for a total of 20 per year. If 10 pride points are not earned before the end of the term, a student will automatically fail advisory and receive a grade of NC for no credit. The advisory credits must be made up by completing 25 additional hours of community service prior to graduation. Completed pride points are submitted by students to and tracked by a student’s advisor.

School activities: Throughout the year Sac High will host various activities for students sponsored by a variety of groups including Student Senate, Dragon Academy, Clubs and other groups. Some of these activities require students to meet the eligibility requirements listed at the bottom of page 18 of this handbook by the official grade check prior to the activity. Some, but not all, of the activities requiring students to meet the academic eligibility requirements are listed below:

- School dances
- Participating in rallies (students who are ineligible may attend the rally, but will not be a participant)
- Powder Puff Football
- Additional events and activities may be included in this category as they arise throughout the year

Here again are the eligibility requirements from pg. 18: Have a minimum 2.0 GPA by the most recent official quarter grade check, have earned a grade of “CR” for credit in advisory and have no more than one NCR. Note that official transcripts will reflect an overall grade of 80%/CR in advisory to indicate credit earned. Refunds will not be made available if a student pays for an activity then is not able to attend due to ineligibility related to GPA, academics or discipline.

School Dances: Periodically throughout the year, school dances are held on either Sacramento Charter High School's campus or at another announced location. To attend a school-sponsored dance:

- Present his or her current Sacramento Charter High School student ID card.
- Arrive no later than the stated time at which the doors will close for the dance.
- Abide by the appropriate, stated dress attire for the dance.
- Be picked up from the dance no later than 15 minutes after the dance has ended. If faculty members must remain with a student to wait for his or her transportation beyond this length of time, the student may not be able to attend the next school activity.
- Tickets may only be paid through Cash or Money Order. No Personal Checks.
- Money will not be refunded if a student gets kicked out of the dance.
- Outside guests for dances, when permitted, must bring proper identification which will be held by Sacramento Charter High School faculty until the dance is over. Guests must abide by Sacramento Charter High School dress and conduct codes for the specific event. Guest permits may not be provided to anyone over the age of eighteen and Sac High reserves the right to refuse access to dances to any guest at any time.
- For most dances, tickets are available for purchase ahead of time in the Sac High Student Store and this may be required for some events. Buying your ticket in advance cuts down on *considerable* waiting time to get into dances.

Clubs: Clubs and activities after school provide students with the opportunity to develop and foster specific interests and to interact with their peers in more relaxed social settings. We also believe that they can cultivate a love of something specific that can enhance their overall academic and school experience. Therefore, we recommend all students participate in at least 2 clubs or extracurricular activities over the course of their 4 years at Sac High. Some of Sac High's clubs are listed below:

34th Street Dance Co.
Key Club
MEChA Club
Health Ambassadors
Ambassadors Club
Media Club
Body Fit
Drama
Drum Line

Lady Majorette's
Student Government
Black Student Union
M.I.S.S.E.S Step Team
Fashion Club
Garden Club
Cooking Club
Lesbian Gay Straight Alliance

Dragon Academy: Dragon Academy is an extension of the regular school day providing academic support services, enrichment opportunities, physical fitness and wellness education and a nutritious meal. Students who attend Dragon Academy are able to complete homework assignments on a daily basis and are exposed to activities that expand horizons. Dragon Academy provides students with leadership opportunities through Student Action Committees, internships, and student-led organizations. Dragon Academy partners with Sacramento Charter High School teachers to offer academic support classes in various subjects including but not limited to English Language Arts, math and CAHSEE Test Prep. Enrichment opportunities are also offered that reinforce and complement the academic program and are based on student needs and interest. These opportunities include but are not limited to visual and performing arts, audio production, project based service learning and intramural sports. Services are provided daily upon the conclusion of the regular school day until at least 6:00 p.m. Services may also be provided before school, during breaks and summer. All services are free for students and families.

ATHLETICS

The purpose of the athletic department is to develop and maintain athletic programs that promote student-athletes and support a well-rounded educational experience, as well as to provide guidance, instill purpose, promote discipline, and build confidence to ensure opportunities for future success in society.

Eligibility: To be academically eligible for California Interscholastic Federation (CIF) participation in interscholastic athletics, students in grades nine through twelve must have a minimum GPA of 2.0 at the last official grade check and be enrolled in a minimum of 20 or more units during the present and previous grading period. Grades earned in summer school or equivalent courses may be used to determine eligibility for fall sports of the subsequent school year. Check page 18 of this handbook for official grade check dates and eligibility requirements.

Age: Student-athletes who turn 19 prior to June 15 of the upcoming school year will be ineligible for athletic participation. To be eligible to play varsity football, students must be at least 15 years of age.

Parent/Guardian Signed Forms: To participate in school athletics, students must get signed and have the following forms:

- 1) Emergency/Participation Information
- 2) Athletics Physical Evaluation Form
- 3) Concussion Info Sheet.

All forms and handbooks can be obtained and returned to the office of the Athletic Director or their designee.

Physical Exam: CIF rules require that all student-athletes provide proof of a current physical exam by a licensed California physician. Physicals are valid for one year only. No student-athlete will be issued a uniform or allowed to participate in athletic practice until evidence of a physical has been provided. Proof of physical and medical release forms will be kept on file in the Athletic Director's office. Physicals must be dated after June 1, 2016, and be valid through May 31, 2017.

Insurance: All Sacramento Charter High School students who wish to participate in athletics are required to have adequate medical and hospitalization insurance before practicing for any of the Dragons' athletic teams. Student-athletes must also have their parent/guardian sign proper medical release/consent-to-treat forms.

Awards & Letters: To receive awards and letters, student-athletes must complete the season in good standing as determined by the head coach and return or account for all equipment checked out to him/her. If the equipment is not returned or accounted for, letters, awards, and pictures may be held by the head coach or Athletic Director until the student's account is cleared by the head coach.

Student-Athlete Expectations: Student-athletes at Sacramento Charter High School are held to high academic and behavior standards including the following:

- Dragon student-athletes will always place a greater emphasis on academics than athletics.
- Athletic participation is a privilege and considered an extracurricular activity. The privilege to participate can be revoked according to the coach's, principal's or principal's designee's discretion at any time.
- Student-athletes will always exhibit good sportsmanship and participate in the spirit of fair play.
- Equipment and facilities must be respected and treated as though they are a student's own and returned in the same condition in which they were issued outside of normal wear and tear.
- Student-athletes, as required by the school and/or coaching staff, may be required to participate in study halls, tutoring sessions, and grade checks to ensure academic success.
- Student-athletes are leaders on the Sacramento Charter High School campus. It is imperative to remember that student-athletes represent their sport, their team and Sacramento Charter High School at all times.
- By choosing to participate in athletics, students make a commitment to their coaches, teammates, and school. Attendance at all practices and games is mandatory. Any reason for missing a scheduled practice or contest must be conveyed to the coach prior to the absence. Consequences given by the school (i.e. JAG, ISS, Friday Night Blues, etc...) supersede any extra-curricular obligations. Student-athletes who miss school based consequences and still participate in athletics during the same time frame will receive additional appropriate consequences.

If a student-athlete fails to abide by these guidelines, s/he will face disciplinary action ranging from nonparticipation in practice and/or part of an entire contest up to dismissal from the team for the season.

Seasons and sports:

Fall Sports	First month of season	Winter Sports	First month of season	Spring Sports	First month of season
Cross Country	August	Basketball (Men's)	November	Baseball	February
Football	August	Basketball (Women's)	November	Softball	February
Golf (Women's)	August	Wrestling	November	Track & Field	February
Volleyball (Women's)	August	Soccer (Men's)	November	Volleyball (Men's)	February
Cheerleading	August	Soccer (Women's)	November	Cheerleading	February

ATTENDANCE

Consistent student attendance is a pre-requisite for academic success. If students are not in school, they will not be able to gain the critical academic and social skills they need. We have the specific goal of better than 95% attendance for all students for the following reasons:

- Students and their families make a significant commitment when they choose to attend Sacramento Charter High School. Part of this commitment is doing whatever it takes to be successful and reach academic success. It's crucial we instill students with a strong work ethic and part of this is ensuring that they come to school each and every day on time and prepared to learn.
- When there are students who come to school after having been absent, they have missed important information. The teachers often must spend time catching those students up, thereby taking valuable time from the class. Our students must understand that their individual attendance is also part of their collective responsibility to classmates and teachers.
- When students are absent and have to spend time catching up, they often are less confident, potentially negatively impacting their attitude toward school and learning.
- Attendance affects our bottom line. Our funding from the state and district are based on our ADA (average daily attendance). When students aren't in school, we lose out on funding. This is significant as these are resources that could be dedicated to more instructional supports and materials.
- Last, and most importantly, when students are not in class they lose out on crucial instructional time. In order to quickly accelerate the learning of all students and move them to proficiency and readiness for college, we must take advantage of every learning opportunity. Being absent from class diminishes our ability to ensure that students are gaining the academic skills they need to be successful.
- Any student, who does not attend at least 80% of his /her classes, may not receive credit for that class.
- Seniors who do not attend 80% of a class in term 2 may not participate in commencement (graduation).

It is our collective responsibility to ensure that we are doing everything possible to encourage the highest levels of attendance. This includes having a clear process in place for students who are not meeting attendance expectations. Specifically, our policies around attendance are:

Tardiness: Any student who is not seated and ready to learn after the bell has rung will be considered unprepared for class and will be marked "UPR" for attendance. Any student who is not in the classroom when the bell concludes is tardy. The student will follow the process for tardy students and will be marked appropriately for the period in attendance with a "T" for tardy. The Attendance Coordinator or designee will determine whether the student is in need of a re-admit or a tardy slip. Excessive tardies will be addressed through discussions with the student, contacting parents/guardians, consequences such as JAG, Friday Night Blues or Saturday School and possibly an attendance contract.

Excused tardies must be handled by the attendance coordinator and must fall into one of the categories that coincide with an excused absence as defined by Education Code 48205 (described below).

Excused Absence: Excused absences are defined in Education Code 48205:

- (a) *Notwithstanding Section 48200 [California's compulsory education requirement], a pupil shall be excused from school when the absence is:*
- (1) *Due to his or her illness.*
 - a) *Note that excessive absences for medical reasons will require a doctor's note to be excused*
 - (2) *Due to quarantine under the direction of a county or city health officer.*
 - (3) *For the purpose of having medical, dental, optometry, or chiropractic services rendered.*

- (4) For the purpose of attending the funeral services of a member of his or her immediate family, so long as the absence is not more than one day if the service is conducted in California and not more than three days if the service is conducted outside California.
- (5) For the purpose of jury duty in the manner provided for by law.
- (6) Due to the illness or medical appointment during school hours of a child of whom the pupil is the custodial parent.
- (7) For justifiable personal reasons, including, but not limited to, an appearance in court, attendance at a funeral service, observance of a holiday or ceremony of his or her religion, attendance at religious retreats, or attendance at an employment conference, when the pupil's absence has been requested in writing by the parent or guardian and approved by the principal or a designated representative pursuant to uniform standards established by the governing board.
- (8) For the purpose of serving as a member of a precinct board for an election pursuant to Section 12302 of the Elections Code.
- (b) A pupil absent from school under this section shall be allowed to complete all assignments and tests missed during the absence that can be reasonably provided and, upon satisfactory completion within a reasonable period of time, shall be given full credit thereof. The teacher of any class from which a pupil is absent shall determine the tests and assignments shall be reasonably equivalent to, but not necessarily identical to, the tests and assignments that the pupil missed during the absence.
- (c) For purposes of this section, attendance at religious retreats shall not exceed four hours per semester.
- (d) Absences pursuant to this section are deemed to be absences in computing average daily attendance and shall not generate state apportionment payments.
- (e) 'Immediate family,' as used in this section, has the same meaning as that set forth in Section 45194, except that references therein to 'employee' shall be deemed to be references to 'pupil.' [Members of the immediate family, as used in this section, means the mother, father, grandmother, grandfather, or a grandchild of the employee or of the spouse of the employee, and the spouse, son, son-in-law, daughter, daughter-in-law, brother, or sister of the employee, or any relative living in the immediate household of the employee.]

Pre-approved Absences: For any extended period of absence from school, students must submit a note signed by their parent/guardian to the Attendance Office prior to their departure or have a parent/guardian phone the Attendance Office prior to departure. Failure to submit an appropriate note or parent/guardian phone verification to the Attendance Office will result in an unexcused absence for the day(s)/class(es) missed.

Early Dismissals: If a student needs to leave school prior to the conclusion of his/her last class, s/he must first obtain an early dismissal from the Attendance Office. Early dismissals will be granted in the event of an emergency only or one of the reasons outlined above in Education Code 48205. Each parent or guardian must sign the student out of campus from the attendance office. If your student rides the bus or walks home, please call in advance notice for early release preparation. All early dismissal slips are issued by the Attendance Office or their designee in case of closure of the Attendance Office. A student who is 18 years of age or older, who lives separately from his/her parents or legal guardian(s), and who has obtained prior consent from the school's attendance office, may sign themselves out for an early dismissal from the attendance office in the event of an emergency only or one of the reasons outlined above in Education Code 48205.

Re-admits: Upon his or her return to school, it is the student's responsibility to (a) obtain a note/call from his or her parent/guardian or (b), have his or her parent/guardian call the Attendance Office to verify the specific days and reasons for the absence. The student must deliver this note/call before the start of the school day to receive a re-admit form which must be taken by the student to all of his or her classes and signed by all of the student's teachers. Students will not be admitted back to class without a readmit. The note/call provides proof of absence and will allow for make-up work to be assigned. The student will be allowed to complete the assigned homework within the same amount of days of the excused absence. Failure to provide appropriate documentation or verification may result in disciplinary action, and will be considered an unexcused absence and thus not be allowed make-up work.

Truancy: Truancy as defined in CA EC Section 48260:

- (a) Any pupil subject to compulsory full-time education or compulsory continuation education who is absent from school without a valid excuse three full days or tardy or absent more than any 30-minute period during the school day without a valid excuse on three occasions in one school year, or any combination thereof, is a truant and shall be reported to the attendance supervisor or the superintendent of the school district.
- **Truancy I:** The first stage of truancy intervention "Truancy I" is triggered after a student is absent from school without a valid excuse more than any 30-minute period during the school day on three occasions. At this time, the parent/guardian shall be notified of "Truancy I" status through a letter. This notice is to make both the student and parent aware of the number of absences and that student may be subject to arrest and/or suspension if found away from home and absent from school without a valid excuse. When a student enters the "Truancy I" phase, s/he may be required to complete appropriate consequences as assigned by an administrator.

- **Truancy 2:** On the next instance of truancy (i.e., any subsequent absence or tardiness without a valid excuse), the student enters the subsequent stage, “Truancy 2” and may be assigned appropriate consequences to make up for missed class time. The student may also be referred to the School Attendance Review Team (SART). If the student fails to attend the SART meeting or fails to complete the program outlined by the school, s/he shall be subject to the process described for the third stage of truancy intervention.
- **Truancy 3:** In the third phase of intervention, “Truancy 3”, the student will be classified as a habitual truant and may be referred to and required to attend another SART meeting or a School Attendance Review Board (SARB) hearing, a truancy mediation program, or comparable program deemed acceptable by the principal or their designee. If the student fails to successfully complete the truancy mediation program or other similar program, the matter may be referred to the District Attorney for prosecution and other appropriate action may be taken by the school.

Attendance at Extracurricular Activities: A student who has been absent from school on a given day may not attend or participate in any extracurricular activities, including athletics, on that day, without the prior permission of the principal or the principal’s designee. In any event, a student must attend at least half of his/her classes on a given day to participate in school activities or athletics. The principal or designee reserves the right to make the final decision. A student who is absent for more than half of his/her classes without an approved excuse on a Friday may not attend Saturday athletics or activities.

Make-up Work for Absences: Students are expected to make up any work missed due to an absence or tardy. Work assigned during preapproved “excused” absences will be due on the day of the student’s return. Lab work, class work and tests assigned during an excused absence will be excused one day for every excused absence day. It is the responsibility of the student to coordinate all missed assignments and make-up work within this time frame.

Absences which are not excused due to illness or school-related activities are considered “unexcused.” This includes student absences for vacations, or other non-emergency absences, which extend beyond designated school holidays and vacation periods. ***Any missed coursework due to an unexcused absence is considered late. Late coursework due to an unexcused absence may be reduced by 50% of the graded score earned on that work (in-class activity, tests, quizzes, projects, assignments, homework, etc.).*** Work assigned prior to an “unexcused” absence may be due on the day of a student’s return. It is the responsibility of the student to immediately coordinate all missed assignments and make-up work on the day of their return. Any delay by the student to coordinate and complete missed assignments may result in the missed work being given a grade of zero.

If students are suspended from school for disciplinary reasons, their absences are deemed “unexcused” and subject to the above academic consequences.

Classroom and homework assignments are the sole responsibility of the student. All students should obtain the telephone numbers of their teachers and other reliable students in each of their classes whom they can contact for missed assignments due to absences. Parents and/or students may request the Attendance Office’s assistance to gather information regarding missed work. A minimum of 24-hour notice is needed to ensure collection of all the missed assignments.

Falsification of Notes and/or Misrepresentation by Phone: Forging a parent’s/guardian’s signature on a note or other communication, altering a note or communication in any way, or making or having someone else make a phone call to the school in which the caller falsely claims to be a parent/guardian is inappropriate and dishonest. Students may be suspended and subject to the school’s suspension and expulsion policy for appropriate consequences for such offenses.

School Dismissal/Student Illness: If a student becomes ill during the school day, he/she should report to the Attendance Office. Every effort will be made to contact the student’s parent/guardian before the student is allowed to leave campus.

For up-to-date and timely information regarding school closure due to natural calamity or emergency situations, please call the main office at (916) 277-6200. Sac High reserves the right to dismiss students early without notice when necessary in the best interest of the school and student(s). Every effort will be made to contact families if this type of situation arises.

STUDENT CONDUCT AND BEHAVIOR

Sacramento Charter High School has high standards for academic achievement and student conduct that are clearly defined, measurable, and do not allow for excuses. Clear and consistent expectations, incentives and consequences are strictly applied and enforced to student and all members of the Sac High community. Sac High students are responsible for their own behavior.

School administrators will ensure that every student who wants to learn will be able to do so in a clean, safe, and productive environment. In return, Sac High students are expected to work hard, have a good attitude, and treat classmates, staff, and visitors with kindness, courtesy, and respect.

A Sacramento Charter High School student is considered a member of the student body at all times and in all places; whether on campus or off campus. As such, we encourage Dragons to always be conscious of his or her actions and show courtesy and respect. Crude language and other expressions of inappropriate conduct are unacceptable. Sacramento Charter High School may, in certain circumstances, review and take action in cases involving student conduct and actions if they are (1) of a nature to bring discredit upon the school; (2) in conflict with the values for which Sacramento Charter High School stands; (3) have the potential to cause a safety risk or disrupt school activities; and/or (4) are in violation of criminal or civil law or the reasonable rights of others.

STUDENT UNIFORM AND DRESS CODE POLICY

Sacramento Charter High School believes that a student's appearance has an impact on his or her attitude, behavior, and readiness to learn. Respect for the school community and for the students themselves is evidenced by dressing appropriately. Sacramento Charter High School students will adhere to a dress code that enhances the educational environment at all times. Our school store has stocked a significant inventory of apparel that meets our specifications. If a student cannot afford the school uniform, the student may, with proper documentation, be provided uniform clothes for free or at a reduced cost. The student may be required to perform work study in exchange for the resources; however, no student will be denied a uniform due to an inability to purchase.

The uniform and dress code policy will be enforced before and during the school day, and after school where/when appropriate. The uniform and dress code policy is required while a student is on campus before and during the school day. After school students must be in appropriate attire, which may be the school uniform, depending on their chosen activity. All staff and teachers will be expected to monitor student compliance to the uniform and dress code policy, address students as needed, and report violations to the appropriate administrator. As with all handbook policies, any changes or updates to the dress code will be communicated to students, families and staff in writing.

Benefits of School Uniforms:

- Establishes a friendly and professional atmosphere that promotes pride, respect & safety
- Instills a sense of community to which students belong
- Decreases violence and theft because of clothing and shoes and creates a level playing field among students
- Helps school officials recognize those who do not belong on campus
- Helps the community identify Sacramento Charter High School students

Consequences of Non-compliance:

If a student is out of compliance with the uniform and dress code policy, appropriate attire may be loaned to the student or parents will be contacted to bring proper uniform items for their child. Students will be required to return any loaned items and serve the appropriate consequences as assigned. Students who fail to return loaned items will be subject to disciplinary action. Students will be removed from class until they are fully compliant with the Sac High uniform and dress code policy. Repeated violations of the uniform and dress code policy may result in a student being sent home at the discretion of the administration. This will be considered a suspension and an "unexcused absences" (see attendance policies starting on pg. 26), and will affect credit received for the day.

Students who are in violation of the uniform and dress code policy but can make the correction will be sent to class once they are fully compliant with the uniform and dress code policy. However, students may be assigned consequences, up to and including suspension and a uniform contract, as deemed appropriate by the administration. In addition, articles of clothing that violate the uniform and dress code policy may be confiscated by administration and returned to students at the end of the day. Students who repeatedly bring prohibited items may have such articles returned only to parents.

Any form of appearance that violates basic norms of neatness and cleanliness, or that may be construed as cultic, gang-related, or causes disunity within the Sacramento Charter High School community, even though conforming to the specific guidelines, is subject to correction by the student at the direction of staff and possible consequences.

Sac High Uniform and Dress Code Policy:

1. All students must have on a black, white or purple Sac High polo shirt from the Sac High student store. Shirts must be completely tucked in at all times outside of approved exceptions (i.e. Physical Education classes)
2. All students must have on khaki pants from the Sac High Student Store
3. All students must have on all black or all white shoes (all visible parts of the shoe, including shoe laces, must be either all black or all white). Shoes must have a back strap around the heel and shall not have a heel more than two inches high.
4. All black or all white socks if wearing socks (all visible parts of the sock must be all either all black or all white)
5. If students choose to wear outerwear over their Sac High polo shirt from the waist up, they must wear one of the following:
 - a. Sac High letterman jacket from the Sac High Student Store
 - b. Sac High all-weather jacket from the Sac High Student Store
 - c. Sac High V-neck sweater from the Sac High Student Store
6. Any undershirt worn underneath a Sac High polo must be solid black, white or purple
7. **Accessories:** Accessories are to be modest, non-distracting, and adhere to the following guidelines:
 - a. Jewelry should be minimal
 - b. Any items worn on a student's head or in a student's hair must be black, white or purple and shall not cover any parts of a student's face. A student's head may not be covered inside.
 - c. Clothing accessories (i.e. belts, scarves) must be non-distracting and be black, white or purple.
 - d. Backpacks and bags may not be red or blue.
8. **Hair:** Hair should be of a natural color, and done in a non-distracting style. Dying, bleaching, adding to (extensions), or tinting hair to a natural color is allowed.
 - a. Unnatural colors or having severely contrasting colors is not permitted.
9. **Additionally, the following protocols must be followed for female and male students at all times:**
 - a. Pants must be worn at the natural waist, and fit appropriately with a belt if needed. All pants must be hemmed (cannot be cut off) and must be free of elastic around the waist and ankles.
 - b. Shirts must be tucked in.
 - c. Hoods and head coverings must remain off indoors at all times, including non-school hours.

Examples of Inappropriate Dress and/or Appearance

1. Altered uniform items (polo shirts, pants, approved outerwear)
2. Clothing other than what has been previously messaged in the uniform and dress code policy.
3. Jean or denim material of any kind.
4. Clothing with derogatory, gang references, offensive and/or lewd messages either in words or pictures.
5. Men and Women's pants that show underwear (sagging). Students may be required to wear a belt.
6. Any overly tight pants
7. Rips, tears, holes, or fraying of clothing including cutoff pants.
8. Hats, do-rags, stocking caps, skullcaps and bandanas are prohibited at all times on the campus of Sacramento Charter High School. Hair scarves, wraps, berets, sweatbands, wave caps, hairnets, curlers, combs, and hair picks are also prohibited.
 - a. Students who need to wear head coverings for religious purposes must contact the Attendance Office to ensure that a letter of religious exception is on file.
9. Head coverings and hoods may not be worn in any building.
 - a. Head coverings (hats, beanies, scarves) may be worn outside of school buildings during inclement weather.
10. Headphones, earphones, phones or any other electronic equipment shall not be visible.
11. Sunglasses shall not be worn in any building.
12. Bare feet.
13. Shoes without a back strap around the heel

14. Shoes or sandals with heels over 2"
15. Grills or decorative stickers/Band-Aids
16. Gloves shall not be worn while inside classrooms
17. PE clothing (EXCEPT in PE)
18. Graffiti on clothing, notebooks, or backpacks.

Dress Code at School Events: Students may be denied admission to various functions if their manner of dress is inappropriate. On this premise, students of Sacramento Charter High School are expected to dress neatly at all times. The following are examples of appropriate dress for various occasions:

1. On campus after school – students are to remain in school uniform (school athletic gear permissible if playing a sport or other appropriate attire depending on the activity)
2. Social/Recreational activities (Games or events) – neat, modest, casual or dressy attire.
3. Formal programs - business or dressy attire.

Professional Dress Attire Days: Occasionally Sacramento Charter High School students may be asked to dress-up and out of regular school dress code by wearing Professional Dress Attire on designated days. When wearing Professional Dress Attire, all students are required throughout the entire school day to abide by the guidelines stated below. Students who are not able to meet this expectation are required to dress in normal school uniform. All hairstyles must be appropriate for a professional setting.

Women

Pants and skirts:

- Khaki, Black, White, Brown, or Purple only
- Loose fitting
- Knee length for skirts

Blouses and dresses:

- Khaki, Black, White, Brown, or Purple only (stripes or professional patterns are allowed)
- Loose fitting
- Ironed
- Free of graphics or logos
- Modest (must not be sheer, low cut, or show bare midriffs)

Shoes:

- White, black or brown
- Be conservative and hold a shine.
- Have less than a 2" heel
- Have a closed back
- (CANNOT wear sandals, flip flops, slippers, military style boots, or athletic shoes)

Sweaters and jackets must:

- Be White, black, purple, brown (stripes or professional patterns are allowed)
- Not be denim material

Men

Required - Slacks or khakis with shirt, tie, and dress shoes

Pants must be:

- White, black, khaki or brown
- Loose fitting

Dress shirts must be:

- White, black, brown or purple (stripes or professional patterns are allowed)
- Loose fitting
- Ironed
- Tucked in
- Free of graphics or logos.

Ties must be:

- Conservative and without inappropriate writing or pictures.

Shoes must:

- White, black or brown
- Be professional, conservative
- Not be sandals, flip flops, slippers, military style boots, or athletic shoes

Sweaters and jackets must:

- White, black, brown or purple (stripes or professional patterns are allowed)
- Not be denim material

Physical Education Uniforms: Sacramento Charter High School students are required to wear uniforms in all physical education classes. Uniforms may be purchased from the Student Store. The shirt and shorts may be purchased individually. Students must have their I.D. card to check out a loaner if one is available. Each student will be assigned a locker. You can bring your own lock or purchase a lock from the Student Store. Big lockers should not be used and all valuables should be locked up in a locker. Non suits (students not in the proper PE uniform) may result in a JAG.

STUDENT BEHAVIORIAL EXPECTATIONS

Creating and preserving a college prep school environment and school culture that is safe, orderly and exemplifies Sac High's Public Schools' Five Pillars and the school's DRAGONS values is a responsibility shared by all adults and students on the Sac High Campus. Consistent implementation of the code of conduct, uniform and dress code and disciplinary procedures detailed in the Student-Parent Handbook requires a collaborative effort from students, families, teachers and staff.

Academic Ethics: For a description of Academic Ethics please see the Academic Policies section of the handbook beginning on page 14.

Bathroom Usage: Students will be allowed to use the restroom during class time with the permission of a teacher or appropriate adult at the time specified by the adult writing the pass. Students are expected to obtain a pass signed by an adult, move quickly, quietly and directly to the restroom and back to class. Signed passes will be in the handbook or in the form of a class restroom pass. Teachers may assign consequences to students who repeatedly miss instruction due to excessive restroom usage (such as repeated trips to the restroom or extended time out of class). Students in this category may be required to use a sign-in/sign-out log to record their time out of class and may also be required to attend sessions after school to ensure they get the missed academic material. Students who abuse this system will be subjected to additional consequences. Students may not use the restroom during the first or last 15 minutes of class and may not use it during the standard advisory period of 25 minutes or they may be subject to appropriate consequences.

During class time, including advisory, if a student is out of class: Students who need to be out of class during class periods or advisory (excluding seniors with an open period) will need the permission of an adult and must have a written pass or be with an appropriate adult. If a student is out of class unaccompanied by an appropriate adult they will be returned to class. If a student does not return to class they will be referred to either the attendance office or the deans per the discretion of the appropriate administrator.

Student Arrival and Departure: Students are **not** to arrive on campus prior to 7:00 a.m. unless they are participating in a supervised activity. The Campus Buildings will be closed at 4:00 p.m. on Mondays, Tuesdays, Thursdays and Fridays and 2:15 p.m. on Wednesdays. The closure time will vary for special days listed on the bell schedule on page 13 of this handbook including minimum days and testing days but will be no less than fifteen minutes after dismissal. Students who remain on campus after campus is closed are required to be participating in an after school program (athletics, Dragon Academy, clubs, tutoring, enrichment, college lab, community service) and be in supervised location for that activity. Students waiting on rides must do so in the front of the school or in another supervised area.

Where can students be and when?

Time of Day	Locations	Appropriate Actions
<p>Before School 7:00-7:55 a.m.</p> <p>IN FULL UNIFORM, ELECTRONICS PERMITTED</p>	<ol style="list-style-type: none"> 1) Main commons 2) Front of School 3) Back patio (by W41-42) 4) Activity supervised by an appropriate adult 5) Walking quickly and quietly to one of the above 	<ol style="list-style-type: none"> 1) Eating breakfast 2) Socializing 3) Preparing for school to start
<p>During Periods 1, 2, 3, 4 and 5 as well as Advisory</p> <p>IN FULL UNIFORM, ELECTRONICS <u>ARE NOT</u> PERMITTED</p>	<ol style="list-style-type: none"> 1) In class 2) If out of class students must be moving quickly and quietly and meet one of the conditions below: <ol style="list-style-type: none"> a. HAVE PASS b. BE WITH AN ADULT c. ON WAY TO THE DEAN'S OR ATTENDANCE OFFICE 	<ol style="list-style-type: none"> 1) Learning in class. 2) Quickly and quietly walking to the appropriate location in an attempt to get back to learning in class as quickly as possible.
<p>During Passing Periods</p> <p>IN FULL UNIFORM, ELECTRONICS <u>ARE NOT</u> PERMITTED</p>	<ol style="list-style-type: none"> 1) Entering/Exiting classrooms 2) Bathroom 3) Walking quickly and quietly to one of the above 	<ol style="list-style-type: none"> 1) Appropriately interacting with others and the facility 2) Snacking/drinking
<p>Lunch Time</p> <p>IN FULL UNIFORM, ELECTRONICS <u>ARE NOT</u> PERMITTED</p>	<ol style="list-style-type: none"> 1) Main Commons 2) In an area supervised by adult (i.e. the patio or garden if supervised) 3) In a class or space with a teacher or another adult 4) Walking quickly and quietly to one of the above 	<ol style="list-style-type: none"> 1) Getting and eating lunch 2) Appropriately interacting with others and the facility 3) Getting ready for class
<p>After School when campus is closed</p> <p>IN UNIFORM OR APPROPRIATE ATTIRE FOR ACTIVITY, ELECTRONICS PERMITTED</p>	<ol style="list-style-type: none"> 1) Front of School – In front of Auditorium after the second bell 2) Dragon Academy 3) Athletics with coach 4) Dean's Office for JAG 5) In a class or space with a teacher or another adult 6) Walking quickly and quietly to one of the above 	<ol style="list-style-type: none"> 1) Waiting for a ride 2) Appropriately interacting with others and the facility 3) Getting help from teacher 4) Serving a consequence 5) Participation in a supervised sport/activity

Seniors on campus with an open period: must report to a supervised and structured program on campus. Students who are found loitering on campus will be sent to the appropriate location or administrator. Seniors may not use cell phones or electronic devices and must follow all school rules, including the uniform and dress code policy, while on campus.

Electronic Devices: Portable stereos, mp3 players, cellular phones, video cameras, any image capturing device and other such devices can impede the learning experience. Such devices are not permitted to be visible or heard on campus beginning

at 7:55 AM and during school hours. This includes passing periods and lunch. If a student is observed or heard with an unapproved electronic device, the device will be confiscated, regardless of the student's reason or explanation, signed into the front office and returned only to the one of the contacts listed on school records. The student will receive JAG as a consequence for having an electronic device confiscated. The confiscated devices may be retrieved from the front office by an administrator. Students who refuse to turn over their electronic devices will be subject to further consequences as outlined in the suspension and expulsion policy.

After a confiscated device has been held by the school for two weeks, staff will attempt to contact the parent/guardian to make arrangements to retrieve the device via phone calls to the parent/guardian, followed by a letter to the student's home. The student's parent/guardian will also be notified that if the device is not retrieved, the confiscated device may be donated to an organization of the school's choosing.

If a student's electronic device is confiscated a second time, the administration has the authority to assess a more severe punishment, including but not limited to, keeping the device for an extended amount of time, multiple JAGs, or suspension.

A phone or recording device may be kept for evidence at any time and for an extended period of time if warranted by administration. Any student who video's a fight subjects them self to consequences per the school's suspension and expulsion policy.

Alcohol: Possession of, use of, consumption of, distribution of, or being under the influence of any alcoholic beverage on campus, on the way to or from school, or at any school function (on or off campus) is strictly prohibited, and makes the student subject to consequences per the school's suspension and expulsion policy. Sacramento Charter High School does not condone student use of any alcoholic beverages at non-school-related functions or gatherings, and reserves the right to address cases involving student conduct and actions, regardless of when or where such actions take place. **There may be times when the school requires a student to undergo drug/alcohol testing and mandates programs or counseling at the parents/guardians' expense.**

Tobacco: Possession of, use of, or distribution of any form of tobacco or tobacco product on campus, or at any school function (on or off campus) is strictly prohibited, and makes the student subject to consequences per the school's suspension and expulsion policy. **There may be times when the school requires a student to undergo drug/alcohol testing and mandates programs or counseling at the parents/guardians' expense.**

Drugs: Possession of, use of, distribution of, manufacturing of, or being under the influence of illegal drugs or unauthorized prescription drugs (e.g., Vicodin, Codeine, etc...) on campus, on the way to or from school, or at any Sacramento Charter High School function is strictly prohibited, and makes the student subject to consequences per the school's suspension and expulsion policy. Sacramento Charter High School does not condone student use of any illegal drugs at non-school-related functions or gatherings, and reserves the right to handle cases involving student conduct and actions, regardless of when or where such actions take place. **There may be times when the school requires a student to undergo drug/alcohol testing and mandates programs or counseling at the parents/guardians' expense.**

Weapons: Weapons of any kind, including paraphernalia such as knives, guns, brass knuckles, chains, lighters, and other such objects that can be used as weapons or in a threatening manner— are not to be brought on campus or to school activities (on or off campus). Any student who brings such items on campus or to school activities is subject to consequences per the school's suspension and expulsion policy.

Gambling: Any form of gambling, whether or not money is visible, is prohibited on campus, on the way to or from campus, or in the surrounding community. Any student who participates in gambling on campus or at school activities is subject to consequences per the school's suspension and expulsion policy.

Gangs: Any affiliation and/or insignias, colors or signs, that may directly affect the safety or disruption of our student body is prohibited on campus or in the surrounding community. Any student involved with the aforementioned violations is subject to consequences per the school's suspension expulsion policy and the SHPS Gang Activity Policy.

Cyber bullying, Harassment and Discriminatory Attacks: Cyber bullying or online bullying is a term used to refer to bullying over electronic media. Cyber bullying is willful and involves recurring or repeated harm inflicted through electronic text. Cyber bullying can be as simple as continuing to send e-mail to someone who has said they want no further contact with the sender. Cyber bullies may also include threats, "putdowns" or hate-motivated speech. Cyber bullies may publish the personal contact information of their victims. They may attempt to assume the identity of a victim for the purpose of publishing material in their name that defames or ridicules them. Any student who is found to have participated in activities described above, sends provocative material/pictures/images of adults or minors, or attempts to be harmful or cruel to

another student or individual through offensive electronic distribution using a cell phone, the Internet, or other electronic devices may be subject to serious disciplinary consequences up to and including expulsion as outlined in the school's suspension and expulsion policy. Serious incidents, including "sexting" or threats, may be turned over to law enforcement authorities.

Identification Cards: Each Sacramento Charter High School student is expected to have his/her student ID card on his/her person at all times while in school or in attendance at any school-related function. Students must be able to produce their ID cards at the request of an authorized person. ID cards must be shown upon request by administration and staff on campus, at games, dances (including prom), and other school-sponsored activities or the student will not be admitted. If the card is lost, a replacement must be obtained in the student store for a fee. If a student is unable to produce his/her ID card upon the request of a staff member, the student may be issued a consequence.

Visitors: Upon arriving, visitors must report to the main office. Visitors are required to sign in and will be announced for their appointment and escorted to the appropriate location. A visitor's pass must be worn and visible at all times. Former Sacramento Charter High Students and Non-Sac High Students will not be permitted on campus during the school day without a verifiable appointment.

Closed Campus: Students must remain on campus during school hours. The only exceptions are students who have an early dismissal slip from the attendance office. Students leaving campus during the school day without approval will be deemed truant and subject to appropriate disciplinary action.

Lunch: Sacramento Charter High School's campus is closed. Students may not leave campus for lunch, and student passes may not be used to go out to lunch or to leave class to pick up a lunch delivered by a parent. Students may bring lunch from home or purchase food in the cafeteria. Students may not order food from outside vendors for delivery during school. In the event that a student forgets his/her lunch, parents may deliver food prepared at home to the front office for their children only. Fast food is not allowed on campus during school hours, even if delivered by a parent or guardian.

Lunchtime: Students are allowed to congregate and eat in the Main Commons or other supervised locations. Students may have access to the library, computer labs, and to available teachers during lunch.

Outside Deliveries: During school, deliveries of outside food (pizza, drinks, etc.), balloons, flowers, or other "special deliveries" by parents, other people, or businesses are not permitted. Such items, including those brought by students, will be stored in the main office until dismissal or in another location deemed permissible by appropriate staff.

Flyers/Literature Distribution: No flyers/literature may be distributed on campus or in the parking lots without the approval of a principal or their designee. The location of distribution may be determined by the administration, and the administration is responsible for checking to make sure all hanging literature has been approved. Flyers may only be posted on campus bulletin boards, concrete pillars in the Commons or other approved locations. The parties distributing flyers/literature are also responsible for taking them down. Failure to do so may result in the loss of the posting privilege.

Parking: Student parking at Sacramento Charter High School is considered a privilege. All students who are eligible to park on campus are required to display a valid parking permit. Students who wish to park on campus must complete a parking application to submit to the front office for approval and park only in spaces approved for student use. Once cars are parked, they should not be accessed at any time during school hours. We reserve the right to revoke parking privileges at any time. Cars that are parked without valid documentation displayed or in an unassigned parking space may be towed. Students who do not receive a permit to park on campus can find sufficient on-street parking on the perimeter of the campus. To request a complete copy of the Sac High parking policy, please contact the main office at (916) 277-6200.

Parking and Driving Regulations: Student parking permits are distributed on a first come, first serve basis. Sacramento Charter High School does not guarantee every student driver a parking permit. Students who do not receive permits should park on the street or make other arrangements. Students must abide by the parking rules and regulations to maintain their parking permits. Drivers are subject to all state and city/county traffic laws, including the reporting of traffic accidents and/or damage to other vehicles. Students must follow all normal traffic rules when parking their vehicles in school parking areas. A parking pass may be revoked at any time at the discretion of the administration.

Field Trips: All field trips must be approved by the principal or the principal's designee. Parent-approved field trip permission slips must be returned to the sponsor of the trip prior to the trip. When a field trip has been planned, the sponsor(s) will notify the student of the dress code for the trip in writing. Unless otherwise noted in writing, students are required to wear their Sacramento Charter High School uniform and abide by the uniform and dress code policy. To request a complete copy of the Sacramento Charter High School field trip policy, please contact the main office at (916) 277-6200.

Library Books /Textbooks: Students are responsible for all library books they check out and all textbooks issued to them by Sacramento Charter High School. Library books and textbooks must be returned in the condition they were received accounting for reasonable wear and tear. The student and the student's parents/guardians are financially responsible for lost, stolen, damaged or destroyed library books and textbooks. Students will be charged up to the full replacement cost for items lost or damaged books. The student may have privileges revoked until outstanding bills for lost or damaged items are paid. Privileges subject to revocation include, but are not limited to, the student's participation in co-curricular and extracurricular activities (such as athletics, commencement, etc.) All outstanding bills for lost or damaged items must also be cleared before diplomas, transcripts, and school records are released.

Student Activities: On-campus clubs, groups, or teams that are not recognized by the administration are prohibited from operating on campus. In order to be recognized and meet on campus, clubs, groups, and teams must file a club charter with the administration. The club charter must include a club constitution and a club budget. For further discussion of applicable rules, please refer to the Sac High Student Advisor/Coach Handbook (ASB handbook), which can be accessed in the main office of Sacramento High. All activities must be supervised by an appropriate adult while using any school facility.

Lost and Found: The Lost and Found is located on campus in the front office. All personal items such as clothing, books, sports equipment, etc., should be clearly labeled with the student's name in indelible ink. Sacramento Charter High School cannot be responsible for any of these items. Items turned into the office that are plainly marked will be returned to the owner. Unmarked items will be placed in Lost and Found. Unclaimed items are donated to local charities periodically.

Personal Property: The school is not responsible for lost or stolen items (including cell phones and other electronic items). The student's name should be placed on all personal items. When a student goes to the gym to dress, all valuables should be locked in a gym locker. Students should guard their combinations and make sure their P.E. lockers are locked.

Abuse: All school personnel are mandated reporters of suspected abuse and/or neglect. Mandated reporters are required to report suspected child maltreatment *immediately* when they have "reasonable cause to believe that a child who is 17 years of age or younger and known to them in a professional or official capacity has been harmed or is in danger of being harmed – physically, sexually, or through neglect – and that a caregiver either committed the harm or should have taken steps to prevent the child from harm."

No one in the workplace, even a supervisor, is permitted to suppress, change, or edit a report of abuse. A mandated reporter who willfully fails to report suspected incidents of child abuse or neglect is subject to license suspension or revocation, and commits a misdemeanor. Falsely reporting information to the hotline is also a misdemeanor.

Harassment Policy: Sac High is committed to providing a safe educational environment that is free from harassment and discrimination for all individuals. All students and employees are forbidden from engaging in any harassing behavior.

The school will investigate allegations of harassment in a prompt, confidential, and thorough manner. Substantiated acts of harassment by staff will result in disciplinary action, up to and including expulsion or termination of employment. Harassment by students will result in consequences being applied through the school's suspension and expulsion policy. Students found to have filed false and frivolous claims of harassment will be subject to disciplinary action as outlined in the school's suspension and expulsion policy.

Harassment occurs when an individual is subjected to treatment or to a school environment that is hostile or intimidating because of that individual's race, creed, color, religion, national origin, age, veteran status, physical disability, gender, or sexual orientation. Sac High will afford equal opportunity to all individuals. Harassment, which can occur any time during school or during school-related activities, includes, but is not limited to, the following:

1. **Verbal Harassment:** Derogatory comments and jokes; epithets; threats; etc...
2. **Physical Harassment:** Unwanted physical touching; intimidating interference with normal work, movement, etc...
3. **Visual Harassment:** Derogatory or inflammatory posters, cartoons, written words, drawings, gestures, etc...
4. **Sexual Harassment:** Includes unwelcome sexual advances, requests for sexual advances or favors, and other verbal or physical conduct of a sexual nature, particularly when any or all of the following occurs:

- Submission to such conduct is made either explicitly or implicitly a term or condition of a student's academic status or progress or is used as a basis of academic decisions concerning the student; or
- Such conduct has the purpose or effect of unreasonably interfering with a student's academic performance or of creating an intimidating, hostile, or offensive educational environment.

Specific examples of sexual harassment include, but are not limited to:

- Making unsolicited sexual advances and propositions;
 - Using sexually degrading words to describe a student or a student's body;
 - Displaying sexually suggestive objects or pictures;
 - Telling inappropriate or sexually related jokes;
 - Making reprisals, or explicit or implied threats of reprisals following a negative response to sexual advances.
5. **Bullying:** one or more acts by a pupil or group of pupils directed against another pupil that constitutes sexual harassment, hate violence, or severe or pervasive intentional harassment, threats, or intimidation that is disruptive, causes disorder, and invades the rights of others by creating an intimidating or hostile educational environment, and includes acts that are committed personally or by means of an electronic act.

It is the responsibility of every individual to: Conduct himself or herself in a manner that contributes to a positive school environment; avoid any activity that may be considered discriminatory, intimidating, or harassing; cease discriminatory, intimidating, harassing, or unwelcome conduct once s/he has been warned of said conduct.

Sexual Intercourse between students: In the state of California, statutory rape is called unlawful sexual intercourse. It is legally defined as an act of sexual intercourse with any minor who is not the spouse of the perpetrator. (PC 261.5(a)) The law is intended to protect males and females alike. A person who is 14 or older and is not more than three years older than the victim is guilty of a misdemeanor. If the person is more than three years older, however, he or she may be found guilty of a felony and punished as an adult with imprisonment in county jail or state prison. Students committing any sexual acts on campus will be subject to consequences per the school's suspension and expulsion policy.

Uniform Complaint Procedure / Complaint Resolution Policy: Sac High has in place a Uniform Complaint Procedure for addressing complaints alleging claims of unlawful discrimination based on ethnicity, religion, age, sex, sexual orientation, color, ancestry, national origin or physical or mental disability, or failure to comply with state and/or federal laws in adult education, consolidated categorical aid programs, migrant education, vocational education, childcare and development programs, child nutrition programs and special education programs. Sac High has also implemented a Complaint Resolution Policy for handling all other complaints. Copies of the Uniform Complaint Procedure, Complaint Resolution Policy and complaint forms are available at the Sac High front office.

Internet Use Policy: Sac High is pleased to offer Internet access for student use. The Internet is to be used solely as a tool for school-related education and research. Using the Internet is a privilege, not a right. This privilege may be revoked at the discretion of the administration. All students and parents of students enrolled in classes at Sac High must read this Internet Use Policy and agree to abide by its terms.

1. **Acceptable Use Policy:** Use of school computers and Internet access must be for educational research and consistent with the objectives and standards of Sac High. Transmission of materials in violation of any federal or state law is prohibited. These include, but are not limited to: copyrighted material, threatening or obscene material, or materials protected by trade-secret law.
2. **Code of Computer Etiquette and Online Conduct:** Any unauthorized person who electronically adds, alters, damages, deletes, or destroys any data, including grades, attendance and/or discipline history, or who knowingly allows another person to engage in such conduct, is subject to suspension, expulsion, and arrest. (E.C. 48900(f), E.C. 48900(g), and Penal Code 502. The next page contains a list of behaviors that are considered violations of Sac High's expectations for computer etiquette and online conduct:
 - a. Intentionally accessing, downloading, displaying, or sending visual or verbal material that is obscene, pornographic, racist, offensive, or harmful to minors.
 - b. Using obscene or profane language.
 - c. Harassing, insulting, or attacking others.

- d. Damaging computers, systems, or networks, including, but not limited to:
- e. Modifying computer control panel settings, spell-checking dictionaries, or other utilities.
- f. Installing, or attempting to install, software without express permission from appropriate authorities.
- g. Changing hardware configuration settings for computers or printers.
- h. Violating copyright laws that include downloading music, videos, etc.
- i. Using other users' passwords to access network resources.
- j. Reviewing or modifying information from the files of administrative systems of Sacramento Charter High School, other schools or other organizations.
- k. Using computer systems for commercial purposes.
- l. Any other activity that may be deemed inappropriate at the discretion of the Sac High administration.

In addition to the above, St. HOPE Public Schools complies with the Children's Internet Protection Act and has in place an Internet Safety Policy that can be obtained at the Sac High front office.

3. **Electronic Mail (E-mail)**. E-mail is defined as a personal electronic message exchanged by the user with another person having Internet access. Users are expected to abide by the Code of Computer Etiquette set forth above. Users are expected to remove old messages in a timely fashion, and system administrators reserve the right to remove such messages if not attended to by the user.
4. **Security**. Users are expected to respect security as a high priority. If a user detects a security problem in any computer, network, or Internet connection, the user must immediately notify a system administrator of the problem without demonstrating said problem to other users. Users may not let others use their account and password. Vandalism will result in cancellation of privileges and/or disciplinary action (up to and including suspension/expulsion). Vandalism is defined as any malicious attempt to harm or destroy data of another user, Sac High, or any agency or network connected to the Internet. It may also include the destruction of, or tampering with, any computer or system network by erasing programs, reconfiguring hard drives, disconnecting from the network, or uploading or creating computer viruses.
5. **Copyright and Public-domain Material**. Copyrighted material must not be placed on any system connected to Sac High without the copyright owner's permission. All users bear sole responsibility for complying with copyright laws.
6. **Technology Disclaimer**. Sac High cannot guarantee smooth operation of its computer systems. It is the student's sole responsibility to complete any required assignments completed by the deadlines set by their teacher(s). Printing problems, loss of data, or other network problems are not considered acceptable excuses for late assignments, absence, or tardiness. It is recommended that students make backup copies of all assignments in print and electronic form.
7. **Enforcement Provisions**. Sac High reserves the right to monitor any and all system activity and to inspect any files, including e-mail, stored on the system. Any and all use of school computers, systems, and networks is not private or protected.
8. **Limitation of Liability**. All policies stated herein are applicable to Sac High's computer facilities. All students and their parent(s)/guardian(s) agree to indemnify and release St. HOPE Public Schools and Sac High, its staff, directors, employees, and all related organizations from any liability, damages, or consequences that may result from the use of the Internet.

Safety in Science Labs: The procedures on the following page are intended to ensure that the Sacramento Charter High School science laboratories are a safe place to learn. It is the student's responsibility to know these procedures and to follow them at all times during lab activities. Any violation of these procedures can put the student and others at risk. Consequences may include immediate removal of the student from the laboratory and zero credit earned for the day's assignments with NO opportunity for make-up, paying for damaged equipment, suspension, and forfeiture of up to and including all lab privileges.

- Read and follow all instructions carefully before beginning a lab. Also, be sure to listen to the teacher and only perform experiments authorized by the teacher.
- You are responsible for your safety and the safety of those around you. Know where all safety equipment is and how to use it properly. Report any accidents, spills or injuries to the teacher immediately.
- Never eat or drink while conducting a lab.
- Conduct yourself in a responsible manner at all times.

- Dress appropriately in the lab. Wear safety equipment (i.e. goggles), closed-toed shoes and tie back long hair when working in the lab. Remove loose jewelry.
- Use care when working with chemicals, open flames, heating devices, sharp instruments, glassware, computers and all other lab equipment. If you are unsure how to use such items, ask for help before beginning to work.
- You are responsible for the materials and equipment that you use. Report any problems before beginning the lab. Use only materials and equipment authorized by your teacher, and don't remove equipment or materials from the lab area.
- Cleanup is your responsibility. Be sure to clean your lab area, dispose of materials appropriately, and return CLEAN equipment to its proper place. Students will only be dismissed once the lab is clean and organized.
- If you miss a lab, it is your responsibility to schedule a make-up lab time or assignment, with your teacher, upon your return to school. If you fail to do so, you will earn a zero for that lab assignment.

DISCIPLINARY PROCEDURES

Creating and preserving a college prep school environment and school culture that is safe, orderly and exemplifies Sac High's Public Schools' Five Pillars and the school's DRAGONS values is a responsibility shared by all adults and students on the Sac High Campus. Consistent implementation of the code of conduct, uniform and dress code policy and disciplinary procedures detailed in the Student-Parent Handbook requires a collaborative effort from teachers, staff, students and families.

Disciplinary Sanctions

The following criteria and processes have been identified for addressing student behavior that does not meet the standards and expectations articulated in the Student Conduct and Behavior section of the handbook. Expectations outlined in the handbook are strictly enforced at school, at school events, and on a student's way to and from school or school events. Additionally, the school expects all students to meet the standards and expectations articulated in the Student Conduct and Behavior section of this handbook at all times while interacting within the community.

Referrals: Students will receive referrals if their behavior disrupts the positive learning environment. Any teacher or staff member may issue a referral. A referral is sent to a dean or appropriate administrator along with the student who is being referred. The dean will review the referral, the student's behavior record, their reflection about the referral, and then make a determination of the appropriate action.

Level 1 Infractions: Level 1 infractions are characterized as minor violations of behavior expectations that disrupt the learning environment. Level 1 infractions include but are not limited to the following:

- Attendance issues such as excessive or deliberate tardiness
- Dress code violation(s)
- Minor Class disturbance(s)
- Use of prohibited electronic devices
- Profanity

Most Level 1 infractions will be handled by the teacher in class. Sac High has zero tolerance for behavior that prevents students from learning and teachers from teaching.

Level 2 Infractions: Level 2 infractions are serious violations of behavior expectations that include but are not limited to the following:

- Repeated or ongoing Level 1 infractions
- Insubordination
- Disrespect
- Excessive profanity
- Disrupting school activities
- Gambling
- Selling items not endorsed by the school. (i.e. Candy)
- Physical disrespect (i.e. play fighting)

Students who commit Level 2 infractions may be referred to a dean or appropriate administrator for disciplinary action via a referral. Students may also be referred by any teacher or staff member, which will also include a referral. A completed referral form must accompany the student as close to the incident as possible. After the dean investigates the incident, the appropriate consequence will be determined. Consequences include but are not limited to JAG, Friday Night Blues, in-house

suspension or other consequences outlined in the school's suspension and expulsion policy. The principal or their designee is the final authority in determining the level of consequence.

Level 3 Infractions: Level 3 violations are major violations of behavior expectations and almost always result in in-house suspension or suspension, and may result in expulsion. Level 3 violations include, but are not limited to the following (see the *St. HOPE Public Schools Suspension and Expulsion Policy* for more detail):

- Fighting and/or causing physical injury
- Possessing, selling, or furnishing of weapons, drugs, tobacco or alcohol
- Property damage or vandalism
- Robbery or extortion
- Harassment/Bullying
- Threatening a student or staff member
- Threatening another person through a text message, email, or social media/Cyber-Bullying
- Videoing a fight
- Instigating a fight
- Verbal Altercation
- Intention to fight
- Gang affiliation, repeated use of symbols, writing, or paraphernalia

Students who commit Level 3 violations will almost always be taken to a dean or appropriate administrator for disciplinary action which will include a referral. Student may be referred by an administrator, teacher, or staff member. A completed referral form must accompany the student. After an investigation into the incident, the appropriate consequence will be determined. The principal or their designee is the final authority in determining the level of consequence.

LEVELS OF CONSEQUENCES

Administration may assign up to any of the consequences listed below. Consequences can be assigned by a teacher or staff member, although a teacher may assign a maximum consequence of a one day suspension from their class.

- **Tier 1**
 - Non-participation in school activities
 - Teacher JAG
 - Lunch JAG
 - Restorative conversation
 - JAG
- **Tier 2**
 - Extended JAG
 - Friday Night Blues
 - Saturday School
- **Tier 3**
 - ISS
 - OSS remainder of the day
 - OSS remainder of the day and the next day
 - OSS 3-5 days
 - Extended suspension due to a recommended expulsion and pending a hearing of the disciplinary panel

Non-Participation in School Activities: Sac High strives to create an environment that is not only focused and disciplined, but fun as well. We believe that our students' high school experiences should be enjoyable and memorable. To that end, we support a number of student activities throughout the school year to create a positive environment on campus.

However, participation in these activities (and others) is a privilege, not a right. Therefore, students who are not meeting expectations in the following ways may not be allowed to participate in school-wide activities:

- Lower than a 2.0 GPA
- Unexcused absence from an assigned consequence
- Poor attendance (students who are in Levels 1-3 of Truancy or who are not achieving an 80% attendance rate)
- Excessive discipline issues as determined by the appropriate administrator
- Students who have been suspended during that Term or school year

Lunch JAG: may be assigned for any number of reasons and is designed to give a measured consequence for student behavior. Ultimately students need to realize that they have control over their behavior. As a result of the student's behavior, the student will be required to perform some on campus clean-up (trash duty after lunch, scraping gum, cleaning the grounds, etc.). Failure to report for lunch JAG will result in additional consequences.

Teacher JAG: may be assigned for any number of reasons and is designed to give a measured consequence for student behavior in the classroom. Ultimately students need to realize that they have control over their behavior in a learning environment. As a result of the student's behavior, the consequence of a Teacher JAG is that the student will be required to participate in a restorative conversation with the teacher afterschool and complete the assignment per the teacher. Students are responsible for communicating with teachers to ensure the Teacher JAG consequence is served prior to the next class period for the specific teacher who assigned the consequence. Failure to report for Teacher JAG the day it is assigned will result in additional consequences.

JAG: JAG ("Justice and Guidance") is the term Sac High uses to refer to detention and is a system for holding students accountable. When a student's actions fall short of the behavior expectations set forth in the Student-Parent Handbook, s/he may be assigned JAG. Any conflicts with attendance in JAG need to be approved by a dean or an appropriate administrator prior to the student leaving for the day and be verified in writing or verbally with all adult parties.

Typically, JAG lasts at least 30 minutes and is held after school at 4:00 p.m. (2:15 p.m. on Wednesdays). Students who are not in the JAG room seated and prepared work at the start time will face additional consequences. During JAG, students may participate in work projects, writing assignments and/or character development activities as assigned.

Extended JAG: When students fail to serve JAG students will be assigned extended JAG which runs 2-3 times per week. Extended JAG is 60 minutes and is housed in the Deans office.

Friday Night Blues: On occasion, students may be assigned to Friday Night Blues, which typically runs on Friday evenings from 4:00 – 6:00 p.m. Friday Night Blues can be the consequence for any level 2 infraction or for repeated smaller infractions. During Friday Night Blues, students may participate in work projects, physical training, writing assignments and/or character development activities as assigned.

Saturday School: On occasion, students may be assigned to Saturday School, which starts on Saturdays at 8:00am. Saturday school can be consequences for any level infraction or for repeated smaller infractions. During Saturday School, students may participate in work projects, physical training, writing assignments and/or character development activities as assigned.

Suspension: A student may receive an in school suspension (ISS) or off site suspension (OSS) when s/he demonstrates an extreme disregard for school rules and policies, chronically violates policies spelled out in the Student Handbook, repeatedly receives lower level consequences with no improvement or repeatedly missed lower level consequences. Suspension will be for one (1) to five (5) school days. A suspension may only be extended past five days if a student is waiting for an expulsion hearing to occur. The principal or their designee determines the length of the suspension and the type of suspension the student receives. See the *St. HOPE Public Schools' Suspension and Expulsion Policy and Procedure* for reference.

Regardless of the length, assignments to suspension do not alter the sequence of disciplinary procedures. For example, if a student is suspended for an offense a second time and s/he then commits the same offense again, the disciplinary action will be considered as the third time. Suspension does not eliminate any previous disciplinary consequences that have not been satisfied, i.e. JAG incurred prior to the beginning of the suspension term.

If suspended, the student's parent/guardian will be informed of the suspension. A conference with the dean or appropriate administrator may be requested before the student returns to school. A suspended student may not be on campus, attend regular classes, any school function or athletic event, or other school activity while on suspension. Suspension may be imposed for any of the following, among others:

- Failing to report to the dean or principal when sent from class for a disciplinary reason
- Acting in any way that could cause personal injury, property damage, or endanger other students, staff or self
- Using or possessing any form of alcohol, drug or tobacco on campus or off campus
- Excessive use of profanity
- Failure to complete ISS
- Fighting on campus or at any school-sponsored affair
- Bullying and/or Cyber Bullying
- Failing to report for JAG or Saturday School

- Failure of past disciplinary action to effectively improved conduct
- Symbols, writing or paraphernalia associated with a gang
- Demonstrating disregard through attitude or actions for teachers, staff, other students, or the Sac High community and/or disrupting the orderly process of learning
- Falsifying notes or phone calls from parents/guardians
- Violating academic ethics such as cheating or plagiarism
- Any other actions deemed serious at the discretion of the principal or the Sac High administration or as described in the ***St. HOPE Public Schools Suspension and Expulsion Policy***.

There are two types of suspension: In-School Suspension and Off Site Suspension. Generally, In-School suspension will be given as an alternative to Off Site Suspension if the offense is lesser and the student will not be a disruption while on campus; however it is the Dean's recommendation and the Principal's or designee's final decision as to which consequence the student in violation will receive.

In-School Suspension (ISS): ISS lasts from 8:00 a.m. until at least 4:00 p.m. and is made up of work detail, academics, and physical activities. Whatever infractions occurred to merit a suspension detracted from the Sac High community and had a negative impact on the school. Therefore, the appropriate consequence is to ensure that students are serving a consequence that is "giving back" to the community in a positive manner. Additionally, students will be responsible for making up all class work and homework for the day. Students will complete all of the academic work they missed during the day.

Off-Site Suspension (OSS): Off-site suspension requires that a student remain completely off campus for the entirety of days assigned, or for the remainder of the day that the suspension is initially assigned. If a student leaves campus prior to the end of a school day for an off-site suspension a parent or guardian will be contacted prior to the student's release. Suspended students are not allowed to attend athletic practices, after school activities, or school events, including off site events, on suspension days. Off-site suspensions are considered unexcused absences and the practices and policies outlined in the attendance section of the Student Handbook, which starts on page 26, apply to suspended students. It is the responsibility of the student to obtain work missed while they are out on suspension.

Expulsion: A student becomes eligible for expulsion when s/he demonstrates an extreme disregard for school rules and policies. See the ***SHPS Suspension and Expulsion Policy and Procedure*** for reference. A principal, dean, administrator, teacher, or staff member may suggest a student be recommended for expulsion; however the principal has the authority to make the final recommendation. An expulsion is when a student is removed from school and all educational programs permanently. A student may be expelled for the following, among others:

- Possessing, using, distributing, or being under the influence of alcoholic beverages, tobacco, illegal drugs, or unauthorized prescription drugs on campus, within view of campus, or at any school function.
- Stealing or committing robbery.
- Fighting or causing physical injury or harm to another person.
- Flagrant insubordination, disobedience, or disregard for legitimate school authority.
- Violating academic ethics such as cheating or plagiarism.
- Possessing, handling, distributing, or selling any object that reasonably can be considered a weapon of any kind: (1) on the school grounds; (2) off the school grounds at any school event; or (3) while in route between home and school.
- Harassing, discriminating, or prejudiced behavior of any kind.
- Threatening or bullying (including cyber bullying)
- Further serious misconduct after being placed on suspension.
- Vandalism, bomb threats, false fire alarms, arson, and/or any other serious disruption to the educational process.
- Falsifying notes or phone calls from parents/guardians or school records.
- Demonstrating disregard for teachers, administrators, other students, the school community and/or disrupting the orderly process of learning or any other infractions as described in the ***St. HOPE Public Schools Suspension/Expulsion Policy***.
- Unlawful possession of school property.
- Gang affiliation or repeated use of gang symbols writing or paraphernalia

Expulsion Process and Disciplinary Administrative Panel: When a student's conduct makes him/her subject to possible expulsion from school, the principal or appropriate member of the administration may make a recommendation to the Disciplinary Administrative Panel for expulsion. Following a hearing and deliberations, the panel will send its recommendation to the Executive Committee of the St. HOPE Public Schools' Board of Directors. The final decision regarding the expulsion of a student is determined by a vote taken by the Executive Committee of the SHPS Board of

Directors. Following the Executive Committee's decision the SHPS Superintendent or designee shall send written notice of the decision to expel, including the panel's findings of facts, to the student's or parent/guardian. See the *SHPS Suspension and Expulsion Policy and Procedure* for reference.

		8	M	9	TU	10	W	
Period 1								
Period 2								
Period 3								
Period 4								
Period 5								
Advisory								
DAILY EVENTS								
HALL PASS	TO:	TO:	TO:	TO:	TO:	TO:	TO:	
	TIME:	TIME:	TIME:	TIME:	TIME:	TIME:	TIME:	
	INITIALS:	INITIALS:	INITIALS:	INITIALS:	INITIALS:	INITIALS:	INITIALS:	

11 TH

12 F

AUGUST

Period 1				
Period 2				
Period 3				
Period 4				
Period 5				
Advisory				
DAILY EVENTS				
HALL PASS	TO:	TO:	TO:	TO:
	TIME:	TIME:	TIME:	TIME:
	INITIALS:	INITIALS:	INITIALS:	INITIALS:

AUGUST 2016					SEPTEMBER 2016									
S	M	T	W	T	F	S	S	M	T	W	T	F	S	
1	2	3	4	5	6							1	2	3
7	8	9	10	11	12	13	4	5	6	7	8	9	10	
14	15	16	17	18	19	20	11	12	13	14	15	16	17	
21	22	23	24	25	26	27	18	19	20	21	22	23	24	
28	29	30	31				25	26	27	28	29	30		

"Patience is bitter, but its fruit is sweet." – Jean Jacques Rousseau

13 SAT

14 SUN

COMMUNITY SERVICE

Did I do C.S. this week? _____

Hours? _____

Verified? _____Y/N_____

SCHOOL PRIDE

		15 M	16 TU	17 W
Period 1				
Period 2				
Period 3				
Period 4				
Period 5				
Advisory				
DAILY EVENTS				
HALL PASS	TO:	TO:	TO:	TO:
	TIME:	TIME:	TIME:	TIME:
	INITIALS:	INITIALS:	INITIALS:	INITIALS:

18 TH

19 F

AUGUST

Period 1	_____		_____	
	_____		_____	
	_____		_____	
	_____		_____	
	_____		_____	
Period 2	_____		_____	
	_____		_____	
	_____		_____	
	_____		_____	
	_____		_____	
Period 3	_____		_____	
	_____		_____	
	_____		_____	
	_____		_____	
	_____		_____	
Period 4	_____		_____	
	_____		_____	
	_____		_____	
	_____		_____	
	_____		_____	
Period 5	_____		_____	
	_____		_____	
	_____		_____	
	_____		_____	
	_____		_____	
Advisory	_____		_____	
	_____		_____	
	_____		_____	
	_____		_____	
	_____		_____	
DAILY EVENTS	_____		_____	
	_____		_____	
	_____		_____	
	_____		_____	
	_____		_____	
HALL PASS	TO: _____	TO: _____	TO: _____	TO: _____
	TIME: _____	TIME: _____	TIME: _____	TIME: _____
	INITIALS: _____	INITIALS: _____	INITIALS: _____	INITIALS: _____

AUGUST					2016					SEPTEMBER					2016									
S	M	T	W	T	F	S	S	M	T	W	T	F	S	S	M	T	W	T	F	S				
	1	2	3	4	5	6													1	2	3			
7	8	9	10	11	12	13	4	5	6	7	8	9	10	14	15	16	17	18	19	20	21	22	23	24
21	22	23	24	25	26	27	18	19	20	21	22	23	24	28	29	30	31	25	26	27	28	29	30	

A KIND person is friendly, helpful and generous.

20 SAT

21 SUN

COMMUNITY SERVICE

Did I do C.S. this week? _____

Hours? _____

Verified? _____ Y/N _____

SCHOOL PRIDE

22 M

23 TU

24 W

Period 1

Period 2

Period 3

Period 4

Period 5

Advisory

DAILY EVENTS

HALL PASS

TO:
TIME:
INITIALS:

TO:
TIME:
INITIALS:

TO:
TIME:
INITIALS:

TO:
TIME:
INITIALS:

TO:
TIME:
INITIALS:

TO:
TIME:
INITIALS:

25 TH

26 F

AUGUST

Period 1

Period 2

Period 3

Period 4

Period 5

Advisory

DAILY EVENTS

HALL PASS

TO:
TIME:
INITIALS:

TO:
TIME:
INITIALS:

TO:
TIME:
INITIALS:

TO:
TIME:
INITIALS:

AUGUST 2016					SEPTEMBER 2016									
S	M	T	W	T	F	S	S	M	T	W	T	F	S	
	1	2	3	4	5	6						1	2	3
7	8	9	10	11	12	13	4	5	6	7	8	9	10	
14	15	16	17	18	19	20	11	12	13	14	15	16	17	
21	22	23	24	25	26	27	18	19	20	21	22	23	24	
28	29	30	31				25	26	27	28	29	30		

You're in line at the grocery store, when the elderly man in front of you spills his coin purse on the floor. What do you do?

27 SAT

28 SUN

COMMUNITY SERVICE

Did I do C.S. this week? _____

Hours? _____

Verified? ____Y/N____

SCHOOL PRIDE

		29	M	30	TU	31	W	
Period 1								
Period 2								
Period 3								
Period 4								
Period 5								
Advisory								
DAILY EVENTS								
HALL PASS	TO:	TO:	TO:	TO:	TO:	TO:	TO:	
	TIME:	TIME:	TIME:	TIME:	TIME:	TIME:	TIME:	
	INITIALS:	INITIALS:	INITIALS:	INITIALS:	INITIALS:	INITIALS:	INITIALS:	

1 TH

2 F

AUGUST

Period 1	_____	_____
	_____	_____
	_____	_____
	_____	_____
	_____	_____
Period 2	_____	_____
	_____	_____
	_____	_____
	_____	_____
	_____	_____
Period 3	_____	_____
	_____	_____
	_____	_____
	_____	_____
	_____	_____
Period 4	_____	_____
	_____	_____
	_____	_____
	_____	_____
	_____	_____
Period 5	_____	_____
	_____	_____
	_____	_____
	_____	_____
	_____	_____
Advisory	_____	_____
	_____	_____
	_____	_____
	_____	_____
	_____	_____
DAILY EVENTS	_____	_____
	_____	_____
	_____	_____
	_____	_____
	_____	_____
HALL PASS	TO: _____	TO: _____
	TIME: _____	TIME: _____
	INITIALS: _____	INITIALS: _____
	TO: _____	TO: _____
	TIME: _____	TIME: _____
	INITIALS: _____	INITIALS: _____

AUGUST 2016							SEPTEMBER 2016							
S	M	T	W	T	F	S	S	M	T	W	T	F	S	
	1	2	3	4	5	6						1	2	3
7	8	9	10	11	12	13	4	5	6	7	8	9	10	
14	15	16	17	18	19	20	11	12	13	14	15	16	17	
21	22	23	24	25	26	27	18	19	20	21	22	23	24	
28	29	30	31				25	26	27	28	29	30		

"Kind words can be short
and easy to speak, but
their echoes are truly
endless." – Mother Teresa

3 SAT

4 SUN

COMMUNITY SERVICE

Did I do C.S. this week? _____

Hours? _____

Verified? _____Y/N_____

SCHOOL PRIDE

		5 M		6 TU		7 W		
Period 1								
Period 2								
Period 3								
Period 4								
Period 5								
Advisory								
DAILY EVENTS	Labor Day							
HALL PASS	TO:	TO:	TO:	TO:	TO:	TO:	TO:	
	TIME:	TIME:	TIME:	TIME:	TIME:	TIME:	TIME:	
	INITIALS:	INITIALS:	INITIALS:	INITIALS:	INITIALS:	INITIALS:	INITIALS:	

8 TH

9 F

SEPTEMBER

Period 1	<hr/> <hr/> <hr/> <hr/>	<hr/> <hr/> <hr/> <hr/>
Period 2	<hr/> <hr/> <hr/> <hr/>	<hr/> <hr/> <hr/> <hr/>
Period 3	<hr/> <hr/> <hr/> <hr/>	<hr/> <hr/> <hr/> <hr/>
Period 4	<hr/> <hr/> <hr/> <hr/>	<hr/> <hr/> <hr/> <hr/>
Period 5	<hr/> <hr/> <hr/> <hr/>	<hr/> <hr/> <hr/> <hr/>
Advisory	<hr/> <hr/> <hr/> <hr/>	<hr/> <hr/> <hr/> <hr/>
DAILY EVENTS	<hr/> <hr/> <hr/> <hr/>	<hr/> <hr/> <hr/> <hr/>
HALL PASS	TO: _____ TIME: _____ INITIALS: _____	TO: _____ TIME: _____ INITIALS: _____

SEPTEMBER					OCTOBER				
S	M	T	W	T	S	M	T	W	T
	1	2	3						1
4	5	6	7	8	2	3	4	5	6
9	10	11	12	13	7	8	9	10	11
14	15	16	17	18	12	13	14	15	16
19	20	21	22	23	17	18	19	20	21
24	25	26	27	28	22	23	24	25	26
29	30				27	28	29	30	31

"If you will think about what you ought to do for other people, your character will take care of itself." - Woodrow Wilson

10 SAT

Eid al-Adha begins at sundown

11 SUN

Patriot Day

COMMUNITY SERVICE

Did I do C.S. this week? _____

Hours? _____

Verified? _____Y/N_____

SCHOOL PRIDE

		12	M	13	TU	14	W	
Period 1								
Period 2								
Period 3								
Period 4								
Period 5								
Advisory								
DAILY EVENTS								
HALL PASS	TO:	TO:	TO:	TO:	TO:	TO:	TO:	
	TIME:	TIME:	TIME:	TIME:	TIME:	TIME:	TIME:	
	INITIALS:	INITIALS:	INITIALS:	INITIALS:	INITIALS:	INITIALS:	INITIALS:	

15 TH

16 F

SEPTEMBER

Period 1				
Period 2				
Period 3				
Period 4				
Period 5				
Advisory				
DAILY EVENTS				
HALL PASS	TO:	TO:	TO:	TO:
	TIME:	TIME:	TIME:	TIME:
	INITIALS:	INITIALS:	INITIALS:	INITIALS:

SEPTEMBER					2016					OCTOBER					2016					
S	M	T	W	T	F	S	S	M	T	W	T	F	S	S	M	T	W	T	F	S
					1	2	3													1
4	5	6	7	8	9	10	2	3	4	5	6	7	8	9	10	11	12	13	14	15
11	12	13	14	15	16	17	9	10	11	12	13	14	15	16	17	18	19	20	21	22
18	19	20	21	22	23	24	16	17	18	19	20	21	22	23	24	25	26	27	28	29
25	26	27	28	29	30									30	31					

THANKFUL people sincerely appreciate what they have.

17 SAT

18 SUN

COMMUNITY SERVICE

Did I do C.S. this week? _____

Hours? _____

Verified? _____Y/N_____

SCHOOL PRIDE

		19 M	20 TU	21 W
Period 1				
Period 2				
Period 3				
Period 4				
Period 5				
Advisory				
DAILY EVENTS				
HALL PASS	TO:	TO:	TO:	TO:
	TIME:	TIME:	TIME:	TIME:
	INITIALS:	INITIALS:	INITIALS:	INITIALS:

22 TH

23 F

SEPTEMBER

Period 1				
Period 2				
Period 3				
Period 4				
Period 5				
Advisory				
DAILY EVENTS	First Day of Autumn			
HALL PASS	TO:	TO:	TO:	TO:
	TIME:	TIME:	TIME:	TIME:
	INITIALS:	INITIALS:	INITIALS:	INITIALS:

SEPTEMBER 2016					OCTOBER 2016								
S	M	T	W	T	F	S	S	M	T	W	T	F	S
			1	2	3							1	
4	5	6	7	8	9	10	2	3	4	5	6	7	8
11	12	13	14	15	16	17	9	10	11	12	13	14	15
18	19	20	21	22	23	24	16	17	18	19	20	21	22
25	26	27	28	29	30		23	24	25	26	27	28	29
							30	31					

A relative gives you a birthday gift that isn't something you wanted. How do you react?

24 SAT

25 SUN

COMMUNITY SERVICE

Did I do C.S. this week? _____

Hours? _____

Verified? _____ Y/N _____

SCHOOL PRIDE

26 M

27 TU

28 W

Period 1

Period 2

Period 3

Period 4

Period 5

Advisory

DAILY EVENTS

HALL PASS

TO:
TIME:
INITIALS:

TO:
TIME:
INITIALS:

TO:
TIME:
INITIALS:

TO:
TIME:
INITIALS:

TO:
TIME:
INITIALS:

TO:
TIME:
INITIALS:

29 TH

30 F

SEPTEMBER

Period 1

Period 2

Period 3

Period 4

Period 5

Advisory

DAILY EVENTS

HALL
PASSTO:
TIME:
INITIALS:TO:
TIME:
INITIALS:TO:
TIME:
INITIALS:TO:
TIME:
INITIALS:

SEPTEMBER		2016		OCTOBER		2016	
S	M	T	W	T	F	S	F
			1	2	3		1
4	5	6	7	8	9	10	2
11	12	13	14	15	16	17	9
18	19	20	21	22	23	24	16
25	26	27	28	29	30		23
							24
							25
							26
							27
							28
							29
							30
							31

"It isn't what's in your pocket that makes you thankful, but what you have in your heart." - Anonymous

1 SAT

Muharram begins at sundown

2 SUN

Rosh Hashanah begins at sundown

COMMUNITY SERVICE

Did I do C.S. this week? _____

Hours? _____

Verified? _____ Y/N _____

SCHOOL PRIDE

		3	M	4	TU	5	W	
Period 1								
Period 2								
Period 3								
Period 4								
Period 5								
Advisory								
DAILY EVENTS								
HALL PASS	TO:	TO:	TO:	TO:	TO:	TO:	TO:	
	TIME:	TIME:	TIME:	TIME:	TIME:	TIME:	TIME:	
	INITIALS:	INITIALS:	INITIALS:	INITIALS:	INITIALS:	INITIALS:	INITIALS:	

6 TH

7 F

OCTOBER

Period 1				
Period 2				
Period 3				
Period 4				
Period 5				
Advisory				
DAILY EVENTS				
HALL PASS	TO:	TO:	TO:	TO:
	TIME:	TIME:	TIME:	TIME:
	INITIALS:	INITIALS:	INITIALS:	INITIALS:

OCTOBER		2016		NOVEMBER		2016							
S	M	T	W	T	F	S	S	M	T	W	T	F	S
						1			1	2	3	4	5
2	3	4	5	6	7	8	6	7	8	9	10	11	12
9	10	11	12	13	14	15	13	14	15	16	17	18	19
16	17	18	19	20	21	22	20	21	22	23	24	25	26
23	24	25	26	27	28	29	27	28	29	30			
30	31												

A COURTEOUS person is polite and respectful.

8 SAT

9 SUN

COMMUNITY SERVICE

Did I do C.S. this week? _____

Hours? _____

Verified? _____ Y/N _____

SCHOOL PRIDE

		10	M	11	TU	12	W	
Period 1								
Period 2								
Period 3								
Period 4								
Period 5								
Advisory								
DAILY EVENTS	Columbus Day (Observed)		Yom Kippur begins at sundown					
HALL PASS	TO:	TO:	TO:	TO:	TO:	TO:	TO:	
	TIME:	TIME:	TIME:	TIME:	TIME:	TIME:	TIME:	
	INITIALS:	INITIALS:	INITIALS:	INITIALS:	INITIALS:	INITIALS:	INITIALS:	

13 TH

14 F

OCTOBER

Period 1

Period 2

Period 3

Period 4

Period 5

Advisory

DAILY EVENTS

HALL PASS

TO: _____
 TIME: _____
 INITIALS: _____

TO: _____
 TIME: _____
 INITIALS: _____

TO: _____
 TIME: _____
 INITIALS: _____

TO: _____
 TIME: _____
 INITIALS: _____

OCTOBER		2016		NOVEMBER		2016	
S	M	T	W	T	F	S	S
						1	
						1	2
2	3	4	5	6	7	8	9
10	11	12	13	14	15	16	17
18	19	20	21	22	23	24	25
26	27	28	29	30	31		

An elderly woman boards the bus and cannot find an open seat. What do you do?

15 SAT

16 SUN

COMMUNITY SERVICE

Did I do C.S. this week? _____

Hours? _____

Verified? _____ Y/N _____

SCHOOL PRIDE

		17	M	18	TU	19	W	
Period 1								
Period 2								
Period 3								
Period 4								
Period 5								
Advisory								
DAILY EVENTS								
HALL PASS	TO:	TO:	TO:	TO:	TO:	TO:	TO:	
	TIME:	TIME:	TIME:	TIME:	TIME:	TIME:	TIME:	
	INITIALS:	INITIALS:	INITIALS:	INITIALS:	INITIALS:	INITIALS:	INITIALS:	

20 TH

21 F

OCTOBER

Period 1				
Period 2				
Period 3				
Period 4				
Period 5				
Advisory				
DAILY EVENTS				
HALL PASS	TO:	TO:	TO:	TO:
	TIME:	TIME:	TIME:	TIME:
	INITIALS:	INITIALS:	INITIALS:	INITIALS:

OCTOBER		2016		NOVEMBER		2016							
S	M	T	W	T	F	S	S	M	T	W	T	F	S
						1			1	2	3	4	5
2	3	4	5	6	7	8	6	7	8	9	10	11	12
9	10	11	12	13	14	15	13	14	15	16	17	18	19
16	17	18	19	20	21	22	20	21	22	23	24	25	26
23	24	25	26	27	28	29	27	28	29	30			
30	31												

"Life is not so short but that there is always time enough for courtesy." - Ralph Waldo Emerson

22 SAT

23 SUN

COMMUNITY SERVICE

Did I do C.S. this week? _____

Hours? _____

Verified? _____ Y/N _____

SCHOOL PRIDE

		24	M	25	TU	26	W	
Period 1								
Period 2								
Period 3								
Period 4								
Period 5								
Advisory								
DAILY EVENTS								
HALL PASS	TO:	TO:	TO:	TO:	TO:	TO:	TO:	
	TIME:	TIME:	TIME:	TIME:	TIME:	TIME:	TIME:	
	INITIALS:	INITIALS:	INITIALS:	INITIALS:	INITIALS:	INITIALS:	INITIALS:	

27 TH

28 F

OCTOBER

Period 1	_____		_____	
	_____		_____	
	_____		_____	
	_____		_____	
	_____		_____	
Period 2	_____		_____	
	_____		_____	
	_____		_____	
	_____		_____	
	_____		_____	
Period 3	_____		_____	
	_____		_____	
	_____		_____	
	_____		_____	
	_____		_____	
Period 4	_____		_____	
	_____		_____	
	_____		_____	
	_____		_____	
	_____		_____	
Period 5	_____		_____	
	_____		_____	
	_____		_____	
	_____		_____	
	_____		_____	
Advisory	_____		_____	
	_____		_____	
	_____		_____	
	_____		_____	
	_____		_____	
DAILY EVENTS	_____		_____	
	_____		_____	
	_____		_____	
	_____		_____	
	_____		_____	
HALL PASS	TO: _____	TO: _____	TO: _____	TO: _____
	TIME: _____	TIME: _____	TIME: _____	TIME: _____
	INITIALS: _____	INITIALS: _____	INITIALS: _____	INITIALS: _____

OCTOBER		2016		NOVEMBER		2016	
S	M	T	W	T	F	S	S
						1	
						1	2 3 4 5
2	3	4	5	6	7	8	6 7 8 9 10 11 12
9	10	11	12	13	14	15	13 14 15 16 17 18 19
16	17	18	19	20	21	22	20 21 22 23 24 25 26
23	24	25	26	27	28	29	27 28 29 30
30	31						

Being ADVENTUROUS means you are willing to take the risk of doing something new.

29 SAT

30 SUN

COMMUNITY SERVICE

Did I do C.S. this week? _____

Hours? _____

Verified? _____Y/N_____

SCHOOL PRIDE

31 | M

1 | TU

2 | W

Period 1

Period 2

Period 3

Period 4

Period 5

Advisory

DAILY EVENTS

Halloween

HALL
PASS

TO:
TIME:
INITIALS:

TO:
TIME:
INITIALS:

TO:
TIME:
INITIALS:

TO:
TIME:
INITIALS:

TO:
TIME:
INITIALS:

TO:
TIME:
INITIALS:

3 TH

4 F

NOVEMBER

Period 1		
Period 2		
Period 3		
Period 4		
Period 5		
Advisory		
DAILY EVENTS		
HALL PASS	TO: TIME: INITIALS:	TO: TIME: INITIALS:

NOVEMBER	2016	DECEMBER	2016											
S	M	T	W	T	F	S	S	M	T	W	T	F	S	
	1	2	3	4	5							1	2	3
6	7	8	9	10	11	12	4	5	6	7	8	9	10	
13	14	15	16	17	18	19	11	12	13	14	15	16	17	
20	21	22	23	24	25	26	18	19	20	21	22	23	24	
27	28	29	30				25	26	27	28	29	30	31	

While at camp, you have the opportunity to go rafting, something you've never done before. What do you do?

5 SAT

6 SUN

Standard Time returns

COMMUNITY SERVICE

Did I do C.S. this week? _____

Hours? _____

Verified? _____Y/N_____

SCHOOL PRIDE

		7 M	8 TU	9 W
Period 1				
Period 2				
Period 3				
Period 4				
Period 5				
Advisory				
DAILY EVENTS			<i>Election Day</i>	
HALL PASS	TO:	TO:	TO:	TO:
	TIME:	TIME:	TIME:	TIME:
	INITIALS:	INITIALS:	INITIALS:	INITIALS:

10 TH

11 F

NOVEMBER

Period 1		
Period 2		
Period 3		
Period 4		
Period 5		
Advisory		
DAILY EVENTS		
HALL PASS	TO: _____ TIME: _____ INITIALS: _____	TO: _____ TIME: _____ INITIALS: _____
	TO: _____ TIME: _____ INITIALS: _____	TO: _____ TIME: _____ INITIALS: _____

NOVEMBER					2016					DECEMBER					2016					
S	M	T	W	T	F	S	S	M	T	W	T	F	S	S	M	T	W	T	F	S
	1	2	3	4	5									1	2	3				
6	7	8	9	10	11	12	4	5	6	7	8	9	10	11	12	13	14	15	16	17
13	14	15	16	17	18	19	18	19	20	21	22	23	24	25	26	27	28	29	30	31
20	21	22	23	24	25	26														
27	28	29	30																	

"Adventure is not outside man; it is within." – David Grayson

12 SAT

13 SUN

COMMUNITY SERVICE

Did I do C.S. this week? _____

Hours? _____

Verified? _____ Y/N _____

SCHOOL PRIDE

Veterans Day

		14 M	15 TU	16 W
Period 1				
Period 2				
Period 3				
Period 4				
Period 5				
Advisory				
DAILY EVENTS				
HALL PASS	TO:	TO:	TO:	TO:
	TIME:	TIME:	TIME:	TIME:
	INITIALS:	INITIALS:	INITIALS:	INITIALS:

17 TH

18 F

NOVEMBER

Period 1	_____		_____	
	_____		_____	
Period 2	_____		_____	
	_____		_____	
Period 3	_____		_____	
	_____		_____	
Period 4	_____		_____	
	_____		_____	
Period 5	_____		_____	
	_____		_____	
Advisory	_____		_____	
	_____		_____	
DAILY EVENTS	_____		_____	
	_____		_____	
HALL PASS	TO: _____	TO: _____	TO: _____	TO: _____
	TIME: _____	TIME: _____	TIME: _____	TIME: _____
	INITIALS: _____	INITIALS: _____	INITIALS: _____	INITIALS: _____

NOVEMBER 2016					DECEMBER 2016									
S	M	T	W	T	F	S	S	M	T	W	T	F	S	
	1	2	3	4	5							1	2	3
6	7	8	9	10	11	12	4	5	6	7	8	9	10	
13	14	15	16	17	18	19	11	12	13	14	15	16	17	
20	21	22	23	24	25	26	18	19	20	21	22	23	24	
27	28	29	30				25	26	27	28	29	30	31	

CHEERFULNESS is the quality of being happy and lively.

19 SAT

20 SUN

COMMUNITY SERVICE

Did I do C.S. this week? _____

Hours? _____

Verified? _____Y/N_____

SCHOOL PRIDE

		21	M	22	TU	23	W	
Period 1								
Period 2								
Period 3								
Period 4								
Period 5								
Advisory								
DAILY EVENTS								
HALL PASS	TO:	TO:	TO:	TO:	TO:	TO:	TO:	
	TIME:	TIME:	TIME:	TIME:	TIME:	TIME:	TIME:	
	INITIALS:	INITIALS:	INITIALS:	INITIALS:	INITIALS:	INITIALS:	INITIALS:	

24 TH

25 F

NOVEMBER

Period 1		
Period 2		
Period 3		
Period 4		
Period 5		
Advisory		
DAILY EVENTS	Thanksgiving	
HALL PASS	TO: _____	TO: _____
	TIME: _____	TIME: _____
	INITIALS: _____	INITIALS: _____

NOVEMBER					2016					DECEMBER					2016					
S	M	T	W	T	F	S	S	M	T	W	T	F	S	S	M	T	W	T	F	S
	1	2	3	4	5							1	2	3						
6	7	8	9	10	11	12	4	5	6	7	8	9	10	11	12	13	14	15	16	17
13	14	15	16	17	18	19	18	19	20	21	22	23	24	25	26	27	28	29	30	31
20	21	22	23	24	25	26														
27	28	29	30																	

A friend is going through a difficult time and seems sad lately. What do you do?

26 SAT

27 SUN

COMMUNITY SERVICE

Did I do C.S. this week? _____

Hours? _____

Verified? _____ Y/N _____

SCHOOL PRIDE

		28	M	29	TU	30	W	
Period 1								
Period 2								
Period 3								
Period 4								
Period 5								
Advisory								
DAILY EVENTS								
HALL PASS	TO:	TO:	TO:	TO:	TO:	TO:	TO:	
	TIME:	TIME:	TIME:	TIME:	TIME:	TIME:	TIME:	
	INITIALS:	INITIALS:	INITIALS:	INITIALS:	INITIALS:	INITIALS:	INITIALS:	

Period 1														
Period 2														
Period 3														
Period 4														
Period 5														
Advisory														
DAILY EVENTS														
HALL PASS	<table style="width: 100%; border-collapse: collapse;"> <tr> <td style="width: 50%; border-bottom: 1px dashed black;">TO: _____</td> <td style="width: 50%; border-bottom: 1px dashed black;">TO: _____</td> </tr> <tr> <td style="border-bottom: 1px dashed black;">TIME: _____</td> <td style="border-bottom: 1px dashed black;">TIME: _____</td> </tr> <tr> <td style="border-bottom: 1px dashed black;">INITIALS: _____</td> <td style="border-bottom: 1px dashed black;">INITIALS: _____</td> </tr> </table>	TO: _____	TO: _____	TIME: _____	TIME: _____	INITIALS: _____	INITIALS: _____	<table style="width: 100%; border-collapse: collapse;"> <tr> <td style="width: 50%; border-bottom: 1px dashed black;">TO: _____</td> <td style="width: 50%; border-bottom: 1px dashed black;">TO: _____</td> </tr> <tr> <td style="border-bottom: 1px dashed black;">TIME: _____</td> <td style="border-bottom: 1px dashed black;">TIME: _____</td> </tr> <tr> <td style="border-bottom: 1px dashed black;">INITIALS: _____</td> <td style="border-bottom: 1px dashed black;">INITIALS: _____</td> </tr> </table>	TO: _____	TO: _____	TIME: _____	TIME: _____	INITIALS: _____	INITIALS: _____
TO: _____	TO: _____													
TIME: _____	TIME: _____													
INITIALS: _____	INITIALS: _____													
TO: _____	TO: _____													
TIME: _____	TIME: _____													
INITIALS: _____	INITIALS: _____													

NOVEMBER	2016	DECEMBER	2016										
S	M	T	W	T	F	S	S	M	T	W	T	F	S
	1	2	3	4	5						1	2	3
6	7	8	9	10	11	12	4	5	6	7	8	9	10
13	14	15	16	17	18	19	11	12	13	14	15	16	17
20	21	22	23	24	25	26	18	19	20	21	22	23	24
27	28	29	30				25	26	27	28	29	30	31

"Cheerfulness is a very great help in fostering the virtue of charity. Cheerfulness itself is a virtue." – Lawrence G. Lovasik

3 SAT

4 SUN

COMMUNITY SERVICE

Did I do C.S. this week? _____

Hours? _____

Verified? _____ Y/N _____

SCHOOL PRIDE

		5 M		6 TU		7 W		
Period 1								
Period 2								
Period 3								
Period 4								
Period 5								
Advisory								
DAILY EVENTS								
HALL PASS	TO:	TO:	TO:	TO:	TO:	TO:	TO:	
	TIME:	TIME:	TIME:	TIME:	TIME:	TIME:	TIME:	
	INITIALS:	INITIALS:	INITIALS:	INITIALS:	INITIALS:	INITIALS:	INITIALS:	

8 TH

9 F

DECEMBER

Period 1					
Period 2					
Period 3					
Period 4					
Period 5					
Advisory					
DAILY EVENTS					
HALL PASS	TO:	TO:	TO:	TO:	
	TIME:	TIME:	TIME:	TIME:	
	INITIALS:	INITIALS:	INITIALS:	INITIALS:	

DECEMBER	2016	JANUARY	2017										
S	M	T	W	T	F	S	S	M	T	W	T	F	S
4	5	6	7	8	9	10	8	9	10	11	12	13	14
11	12	13	14	15	16	17	15	16	17	18	19	20	21
18	19	20	21	22	23	24	22	23	24	25	26	27	28
25	26	27	28	29	30	31	29	30	31				

A FLEXIBLE person is willing to alter plans when necessary.

10 SAT

11 SUN

Mawlid al-Nabi begins at sundown

COMMUNITY SERVICE

Did I do C.S. this week? _____

Hours? _____

Verified? _____Y/N_____

SCHOOL PRIDE

		12	M	13	TU	14	W	
Period 1								
Period 2								
Period 3								
Period 4								
Period 5								
Advisory								
DAILY EVENTS								
HALL PASS	TO:	TO:	TO:	TO:	TO:	TO:	TO:	
	TIME:	TIME:	TIME:	TIME:	TIME:	TIME:	TIME:	
	INITIALS:	INITIALS:	INITIALS:	INITIALS:	INITIALS:	INITIALS:	INITIALS:	

15 TH

16 F

DECEMBER

Period 1

Period 2

Period 3

Period 4

Period 5

Advisory

DAILY EVENTS

HALL PASS

TO: _____
TIME: _____
INITIALS: _____

TO: _____
TIME: _____
INITIALS: _____

TO: _____
TIME: _____
INITIALS: _____

TO: _____
TIME: _____
INITIALS: _____

DECEMBER					2016					JANUARY					2017					
S	M	T	W	T	F	S	S	M	T	W	T	F	S	S	M	T	W	T	F	S
							1	2	3	4	5	6	7	8	9	10	11	12	13	14
4	5	6	7	8	9	10	15	16	17	18	19	20	21	22	23	24	25	26	27	28
18	19	20	21	22	23	24	29	30	31											
25	26	27	28	29	30	31														

You've been looking forward to playing soccer with your friends, but it rains all day and floods the field. What do you do?

17 SAT

18 SUN

COMMUNITY SERVICE

Did I do C.S. this week? _____

Hours? _____

Verified? _____ Y/N _____

SCHOOL PRIDE

		19 M	20 TU	21 W
Period 1				
Period 2				
Period 3				
Period 4				
Period 5				
Advisory				
DAILY EVENTS				
HALL PASS	TO:	TO:	TO:	TO:
	TIME:	TIME:	TIME:	TIME:
	INITIALS:	INITIALS:	INITIALS:	INITIALS:
				First Day of Winter

22 TH

23 F

DECEMBER

Period 1				
Period 2				
Period 3				
Period 4				
Period 5				
Advisory				
DAILY EVENTS				
HALL PASS	TO:	TO:	TO:	TO:
	TIME:	TIME:	TIME:	TIME:
	INITIALS:	INITIALS:	INITIALS:	INITIALS:

DECEMBER					2016					JANUARY					2017																								
S	M	T	W	T	F	S	S	M	T	W	T	F	S	S	M	T	W	T	F	S																			
					1	2	3	4	5	6	7	8	9	10	11	12	13	14	15	16	17	18	19	20	21	22	23	24	25	26	27	28	29	30	31				

"Stay committed to your decisions, but stay flexible in your approach." - Tony Robbins

24 SAT

Hanukkah begins at sundown

25 SUN

Christmas

COMMUNITY SERVICE

Did I do C.S. this week? _____

Hours? _____

Verified? _____Y/N_____

SCHOOL PRIDE

26 M

27 TU

28 W

Period 1

Period 2

Period 3

Period 4

Period 5

Advisory

DAILY EVENTS

Kwanzaa begins

HALL
PASS

TO:
TIME:
INITIALS:

TO:
TIME:
INITIALS:

TO:
TIME:
INITIALS:

TO:
TIME:
INITIALS:

TO:
TIME:
INITIALS:

TO:
TIME:
INITIALS:

29 TH

30 F

DECEMBER

Period 1	_____		_____	
	_____		_____	
	_____		_____	
	_____		_____	
	_____		_____	
Period 2	_____		_____	
	_____		_____	
	_____		_____	
	_____		_____	
	_____		_____	
Period 3	_____		_____	
	_____		_____	
	_____		_____	
	_____		_____	
	_____		_____	
Period 4	_____		_____	
	_____		_____	
	_____		_____	
	_____		_____	
	_____		_____	
Period 5	_____		_____	
	_____		_____	
	_____		_____	
	_____		_____	
	_____		_____	
Advisory	_____		_____	
	_____		_____	
	_____		_____	
	_____		_____	
	_____		_____	
DAILY EVENTS	_____		_____	
	_____		_____	
	_____		_____	
	_____		_____	
	_____		_____	
HALL PASS	TO: _____	TO: _____	TO: _____	TO: _____
	TIME: _____	TIME: _____	TIME: _____	TIME: _____
	INITIALS: _____	INITIALS: _____	INITIALS: _____	INITIALS: _____

DECEMBER					2016					JANUARY					2017						
S	M	T	W	T	F	S	S	M	T	W	T	F	S	S	M	T	W	T	F	S	
					1	2	3	4	5	6	7	1	2	3	4	5	6	7	8	9	
4	5	6	7	8	9	10	8	9	10	11	12	13	14	15	16	17	18	19	20	21	22
18	19	20	21	22	23	24	22	23	24	25	26	27	28	29	30	31					
25	26	27	28	29	30	31	29	30	31												

A MORAL person acts in ways that are honest and good.

31 SAT

1 SUN

New Year's Day

COMMUNITY SERVICE

Did I do C.S. this week? _____

Hours? _____

Verified? _____ Y/N _____

SCHOOL PRIDE

		2 M		3 TU		4 W		
Period 1								
Period 2								
Period 3								
Period 4								
Period 5								
Advisory								
DAILY EVENTS								
HALL PASS	TO:	TO:	TO:	TO:	TO:	TO:	TO:	
	TIME:	TIME:	TIME:	TIME:	TIME:	TIME:	TIME:	
	INITIALS:	INITIALS:	INITIALS:	INITIALS:	INITIALS:	INITIALS:	INITIALS:	

Period 1		
Period 2		
Period 3		
Period 4		
Period 5		
Advisory		
DAILY EVENTS		
HALL PASS	TO: _____ TO: _____ TIME: _____ TIME: _____ INITIALS: _____ INITIALS: _____	TO: _____ TO: _____ TIME: _____ TIME: _____ INITIALS: _____ INITIALS: _____

JANUARY 2017					FEBRUARY 2017								
S	M	T	W	T	F	S	S	M	T	W	T	F	S
1	2	3	4	5	6	7				1	2	3	4
8	9	10	11	12	13	14	5	6	7	8	9	10	11
15	16	17	18	19	20	21	12	13	14	15	16	17	18
22	23	24	25	26	27	28	19	20	21	22	23	24	25
29	30	31					26	27	28				

You receive credit for another student's idea. What do you do?

7 SAT

--	--

8 SUN

--	--

COMMUNITY SERVICE

Did I do C.S. this week? _____

Hours? _____

Verified? _____ Y/N _____

SCHOOL PRIDE

		9 M	10 TU	11 W
Period 1				
Period 2				
Period 3				
Period 4				
Period 5				
Advisory				
DAILY EVENTS				
HALL PASS	TO:	TO:	TO:	TO:
	TIME:	TIME:	TIME:	TIME:
	INITIALS:	INITIALS:	INITIALS:	INITIALS:

12 TH

13 F

JANUARY

Period 1				
Period 2				
Period 3				
Period 4				
Period 5				
Advisory				
DAILY EVENTS				
HALL PASS	TO:	TO:	TO:	TO:
	TIME:	TIME:	TIME:	TIME:
	INITIALS:	INITIALS:	INITIALS:	INITIALS:

JANUARY 2017					FEBRUARY 2017										
S	M	T	W	T	F	S	S	M	T	W	T	F	S		
1	2	3	4	5	6	7						1	2	3	4
8	9	10	11	12	13	14	5	6	7	8	9	10	11		
15	16	17	18	19	20	21	12	13	14	15	16	17	18		
22	23	24	25	26	27	28	19	20	21	22	23	24	25		
29	30	31					26	27	28						

"If moral behavior were simply following rules, we could program a computer to be moral." - Samuel P. Ginder

14 SAT

15 SUN

COMMUNITY SERVICE

Did I do C.S. this week? _____

Hours? _____

Verified? _____Y/N_____

SCHOOL PRIDE

16 M

17 TU

18 W

Period 1

Period 2

Period 3

Period 4

Period 5

Advisory

DAILY EVENTS

Martin Luther King, Jr. Day (Observed)

HALL PASS

TO:	TO:
TIME:	TIME:
INITIALS:	INITIALS:

TO:	TO:
TIME:	TIME:
INITIALS:	INITIALS:

TO:	TO:
TIME:	TIME:
INITIALS:	INITIALS:

19 TH

20 F

JANUARY

Period 1		
Period 2		
Period 3		
Period 4		
Period 5		
Advisory		
DAILY EVENTS		
HALL PASS	TO: _____ TIME: _____ INITIALS: _____	TO: _____ TIME: _____ INITIALS: _____
	TO: _____ TIME: _____ INITIALS: _____	TO: _____ TIME: _____ INITIALS: _____
	TO: _____ TIME: _____ INITIALS: _____	TO: _____ TIME: _____ INITIALS: _____

JANUARY					2017					FEBRUARY					2017											
S	M	T	W	T	F	S	S	M	T	W	T	F	S	S	M	T	W	T	F	S						
1	2	3	4	5	6	7						1	2	3	4											
8	9	10	11	12	13	14	5	6	7	8	9	10	11	12	13	14	15	16	17	18						
15	16	17	18	19	20	21	19	20	21	22	23	24	25	26	27	28	29	30	31							
22	23	24	25	26	27	28								26	27	28										
29	30	31																								

CURIOSITY is a desire to investigate and seek understanding of your world.

21 SAT

22 SUN

COMMUNITY SERVICE

Did I do C.S. this week? _____

Hours? _____

Verified? _____Y/N_____

SCHOOL PRIDE

23 M

24 TU

25 W

Period 1

Period 2

Period 3

Period 4

Period 5

Advisory

DAILY EVENTS

HALL PASS

TO:
TIME:
INITIALS:

TO:
TIME:
INITIALS:

TO:
TIME:
INITIALS:

TO:
TIME:
INITIALS:

TO:
TIME:
INITIALS:

TO:
TIME:
INITIALS:

Period 1				
Period 2				
Period 3				
Period 4				
Period 5				
Advisory				
DAILY EVENTS				
HALL PASS	TO:	TO:	TO:	TO:
	TIME:	TIME:	TIME:	TIME:
	INITIALS:	INITIALS:	INITIALS:	INITIALS:

JANUARY 2017					FEBRUARY 2017										
S	M	T	W	T	F	S	S	M	T	W	T	F	S		
1	2	3	4	5	6	7						1	2	3	4
8	9	10	11	12	13	14	5	6	7	8	9	10	11		
15	16	17	18	19	20	21	12	13	14	15	16	17	18		
22	23	24	25	26	27	28	19	20	21	22	23	24	25		
29	30	31					26	27	28						

You're assigned to research a country in Africa that you've never heard of before. What do you do?

28 SAT

Chinese New Year

29 SUN

COMMUNITY SERVICE

Did I do C.S. this week? _____

Hours? _____

Verified? _____Y/N_____

SCHOOL PRIDE

		30	M	31	TU	1	W	
Period 1								
Period 2								
Period 3								
Period 4								
Period 5								
Advisory								
DAILY EVENTS								
HALL PASS	TO:	TO:	TO:	TO:	TO:	TO:	TO:	
	TIME:	TIME:	TIME:	TIME:	TIME:	TIME:	TIME:	
	INITIALS:	INITIALS:	INITIALS:	INITIALS:	INITIALS:	INITIALS:	INITIALS:	

2 TH

3 F

FEBRUARY

Period 1				
Period 2				
Period 3				
Period 4				
Period 5				
Advisory				
DAILY EVENTS	Groundhog Day			
HALL PASS	TO:	TO:	TO:	TO:
	TIME:	TIME:	TIME:	TIME:
	INITIALS:	INITIALS:	INITIALS:	INITIALS:

FEBRUARY					2017					MARCH					2017																									
S	M	T	W	T	F	S	S	M	T	W	T	F	S	S	M	T	W	T	F	S																				
			1	2	3	4							5	6	7	8	9	10	11	12	13	14	15	16	17	18	19	20	21	22	23	24	25	26	27	28				

"Curiosity is the wick in the candle of learning."
- William Arthur Ward

4 SAT

--	--

5 SUN

--	--

COMMUNITY SERVICE

Did I do C.S. this week? _____

Hours? _____

Verified? _____Y/N_____

SCHOOL PRIDE

		6 M		7 TU		8 W		
Period 1								
Period 2								
Period 3								
Period 4								
Period 5								
Advisory								
DAILY EVENTS								
HALL PASS	TO:	TO:	TO:	TO:	TO:	TO:	TO:	
	TIME:	TIME:	TIME:	TIME:	TIME:	TIME:	TIME:	
	INITIALS:	INITIALS:	INITIALS:	INITIALS:	INITIALS:	INITIALS:	INITIALS:	

9 TH

10 F

FEBRUARY

Period 1				
Period 2				
Period 3				
Period 4				
Period 5				
Advisory				
DAILY EVENTS				
HALL PASS	TO:	TO:	TO:	TO:
	TIME:	TIME:	TIME:	TIME:
	INITIALS:	INITIALS:	INITIALS:	INITIALS:

FEBRUARY					2017					MARCH					2017												
S	M	T	W	T	F	S	S	M	T	W	T	F	S	S	M	T	W	T	F	S							
			1	2	3	4							5	6	7	8	9	10	11			1	2	3	4		
5	6	7	8	9	10	11	5	6	7	8	9	10	11	12	13	14	15	16	17	18	12	13	14	15	16	17	18
19	20	21	22	23	24	25	19	20	21	22	23	24	25	19	20	21	22	23	24	25	19	20	21	22	23	24	25
26	27	28					26	27	28	29	30	31		26	27	28	29	30	31		26	27	28	29	30	31	

A PROACTIVE person initiates positive change.

11 SAT

12 SUN

Lincoln's Birthday

COMMUNITY SERVICE

Did I do C.S. this week? _____

Hours? _____

Verified? _____ Y/N _____

SCHOOL PRIDE

13 M

14 TU

15 W

Period 1

Period 2

Period 3

Period 4

Period 5

Advisory

DAILY EVENTS

Valentine's Day

HALL PASS

TO:	TO:
TIME:	TIME:
INITIALS:	INITIALS:

TO:	TO:
TIME:	TIME:
INITIALS:	INITIALS:

TO:	TO:
TIME:	TIME:
INITIALS:	INITIALS:

16 TH

17 F

FEBRUARY

Period 1				
Period 2				
Period 3				
Period 4				
Period 5				
Advisory				
DAILY EVENTS				
HALL PASS	TO: _____	TO: _____	TO: _____	TO: _____
	TIME: _____	TIME: _____	TIME: _____	TIME: _____
	INITIALS: _____	INITIALS: _____	INITIALS: _____	INITIALS: _____

FEBRUARY					2017					MARCH					2017												
S	M	T	W	T	F	S	S	M	T	W	T	F	S	S	M	T	W	T	F	S							
			1	2	3	4							5	6	7	8	9	10	11			1	2	3	4		
5	6	7	8	9	10	11	5	6	7	8	9	10	11	12	13	14	15	16	17	18	12	13	14	15	16	17	18
12	13	14	15	16	17	18	12	13	14	15	16	17	18	19	20	21	22	23	24	25	19	20	21	22	23	24	25
19	20	21	22	23	24	25	19	20	21	22	23	24	25	26	27	28	26	27	28	29	30	31					

The local food pantry anticipates an increase in demand over the next few months. What can you do?

18 SAT

19 SUN

COMMUNITY SERVICE

Did I do C.S. this week? _____

Hours? _____

Verified? _____ Y/N _____

SCHOOL PRIDE

		20	M	21	TU	22	W	
Period 1								
Period 2								
Period 3								
Period 4								
Period 5								
Advisory								
DAILY EVENTS	<i>Presidents' Day</i>				<i>Washington's Birthday</i>			
HALL PASS	TO:	TO:	TO:	TO:	TO:	TO:	TO:	
	TIME:	TIME:	TIME:	TIME:	TIME:	TIME:	TIME:	
	INITIALS:	INITIALS:	INITIALS:	INITIALS:	INITIALS:	INITIALS:	INITIALS:	

23 TH

24 F

FEBRUARY

Period 1		
Period 2		
Period 3		
Period 4		
Period 5		
Advisory		
DAILY EVENTS		
HALL PASS	TO: _____	TO: _____
	TIME: _____	TIME: _____
	INITIALS: _____	INITIALS: _____

FEBRUARY					2017					MARCH					2017					
S	M	T	W	T	F	S	S	M	T	W	T	F	S	S	M	T	W	T	F	S
					1	2	3	4				1	2	3	4				5	6
5	6	7	8	9	10	11	5	6	7	8	9	10	11	12	13	14	15	16	17	18
19	20	21	22	23	24	25	19	20	21	22	23	24	25	26	27	28	29	30	31	

"We must look for ways to be an active force in our own lives. We must take charge of our own destinies." - Les Brown

25 SAT

26 SUN

COMMUNITY SERVICE

Did I do C.S. this week? _____

Hours? _____

Verified? _____ Y/N _____

SCHOOL PRIDE

27 M

28 TU

1 W

Period 1

Period 2

Period 3

Period 4

Period 5

Advisory

DAILY EVENTS

HALL PASS

TO:
TIME:
INITIALS:

TO:
TIME:
INITIALS:

TO:
TIME:
INITIALS:

TO:
TIME:
INITIALS:

TO:
TIME:
INITIALS:

TO:
TIME:
INITIALS:

Ash Wednesday

2 TH

3 F

MARCH

Period 1		
Period 2		
Period 3		
Period 4		
Period 5		
Advisory		
DAILY EVENTS		
HALL PASS	TO: _____ TIME: _____ INITIALS: _____	TO: _____ TIME: _____ INITIALS: _____

MARCH							2017							APRIL							2017						
S	M	T	W	T	F	S	S	M	T	W	T	F	S	S	M	T	W	T	F	S	S	M	T	W	T	F	S
							1	2	3	4											1						
5	6	7	8	9	10	11								2	3	4	5	6	7	8							
12	13	14	15	16	17	18								9	10	11	12	13	14	15							
19	20	21	22	23	24	25								16	17	18	19	20	21	22							
26	27	28	29	30	31									23	24	25	26	27	28	29							
														30													

RESPECT is a feeling of admiration for someone.

4 SAT

5 SUN

COMMUNITY SERVICE

Did I do C.S. this week? _____

Hours? _____

Verified? _____ Y/N _____

SCHOOL PRIDE

		6 M		7 TU		8 W		
Period 1								
Period 2								
Period 3								
Period 4								
Period 5								
Advisory								
DAILY EVENTS								
HALL PASS	TO:	TO:	TO:	TO:	TO:	TO:	TO:	
	TIME:	TIME:	TIME:	TIME:	TIME:	TIME:	TIME:	
	INITIALS:	INITIALS:	INITIALS:	INITIALS:	INITIALS:	INITIALS:	INITIALS:	

9 TH

10 F

MARCH

Period 1					
Period 2					
Period 3					
Period 4					
Period 5					
Advisory					
DAILY EVENTS					
HALL PASS	TO:	TO:	TO:	TO:	
	TIME:	TIME:	TIME:	TIME:	
	INITIALS:	INITIALS:	INITIALS:	INITIALS:	

MARCH							2017							APRIL							2017						
S	M	T	W	T	F	S	S	M	T	W	T	F	S	S	M	T	W	T	F	S	S	M	T	W	T	F	S
							1	2	3	4																	1
5	6	7	8	9	10	11	12	13	14	15	16	17	18	2	3	4	5	6	7	8	9	10	11	12	13	14	15
19	20	21	22	23	24	25	26	27	28	29	30	31		16	17	18	19	20	21	22	23	24	25	26	27	28	29
																					30						

During a convocation, your classmates are passing notes and talking. They try to get you to join in. What do you do?

11 SAT

12 SUN

Daylight-Saving Time begins

COMMUNITY SERVICE

Did I do C.S. this week? _____

Hours? _____

Verified? _____ Y/N _____

SCHOOL PRIDE

		13 M	14 TU	15 W
Period 1				
Period 2				
Period 3				
Period 4				
Period 5				
Advisory				
DAILY EVENTS				
HALL PASS	TO:	TO:	TO:	TO:
	TIME:	TIME:	TIME:	TIME:
	INITIALS:	INITIALS:	INITIALS:	INITIALS:

16 TH

17 F

MARCH

Period 1

Period 2

Period 3

Period 4

Period 5

Advisory

DAILY EVENTS

HALL PASS

TO:
TIME:
INITIALS:

TO:
TIME:
INITIALS:

TO:
TIME:
INITIALS:

TO:
TIME:
INITIALS:

MARCH					2017					APRIL					2017					
S	M	T	W	T	F	S	S	M	T	W	T	F	S	S	M	T	W	T	F	S
					1	2	3	4												1
5	6	7	8	9	10	11	2	3	4	5	6	7	8	9	10	11	12	13	14	15
12	13	14	15	16	17	18	9	10	11	12	13	14	15	16	17	18	19	20	21	22
19	20	21	22	23	24	25	16	17	18	19	20	21	22	23	24	25	26	27	28	29
26	27	28	29	30	31		23	24	25	26	27	28	29	30						

“Being brilliant is no great feat if you respect nothing.” – Johann Wolfgang von Goethe

18 SAT

19 SUN

COMMUNITY SERVICE

Did I do C.S. this week? _____

Hours? _____

Verified? _____Y/N_____

SCHOOL PRIDE

St. Patrick's Day

		20	M	21	TU	22	W	
Period 1								
Period 2								
Period 3								
Period 4								
Period 5								
Advisory								
DAILY EVENTS	<i>First Day of Spring</i>							
HALL PASS	TO:	TO:	TO:	TO:	TO:	TO:	TO:	
	TIME:	TIME:	TIME:	TIME:	TIME:	TIME:	TIME:	
	INITIALS:	INITIALS:	INITIALS:	INITIALS:	INITIALS:	INITIALS:	INITIALS:	

23 TH

24 F

MARCH

Period 1

Period 2

Period 3

Period 4

Period 5

Advisory

DAILY EVENTS

HALL PASS

TO: _____
TIME: _____
INITIALS: _____

TO: _____
TIME: _____
INITIALS: _____

TO: _____
TIME: _____
INITIALS: _____

TO: _____
TIME: _____
INITIALS: _____

MARCH					2017					APRIL					2017					
S	M	T	W	T	F	S	S	M	T	W	T	F	S	S	M	T	W	T	F	S
					1	2	3	4					1							
5	6	7	8	9	10	11							2	3	4	5	6	7	8	
12	13	14	15	16	17	18							9	10	11	12	13	14	15	
19	20	21	22	23	24	25							16	17	18	19	20	21	22	
26	27	28	29	30	31							23	24	25	26	27	28	29	30	

VIRTUOUS people act according to their morals.

25 SAT

26 SUN

COMMUNITY SERVICE

Did I do C.S. this week? _____

Hours? _____

Verified? _____ Y/N _____

SCHOOL PRIDE

27 M

28 TU

29 W

Period 1

Period 2

Period 3

Period 4

Period 5

Advisory

DAILY EVENTS

HALL PASS

TO:
TIME:
INITIALS:

TO:
TIME:
INITIALS:

TO:
TIME:
INITIALS:

TO:
TIME:
INITIALS:

TO:
TIME:
INITIALS:

TO:
TIME:
INITIALS:

30 TH

31 F

MARCH

MARCH		2017		APRIL		2017							
S	M	T	W	T	F	S	S	M	T	W	T	F	S
		1	2	3	4								1
5	6	7	8	9	10	11	2	3	4	5	6	7	8
12	13	14	15	16	17	18	9	10	11	12	13	14	15
19	20	21	22	23	24	25	16	17	18	19	20	21	22
26	27	28	29	30	31		23	24	25	26	27	28	29
													30

You and a friend are counting ballots for a student election. Your friend wants to alter the results. What do you do?

1 SAT

April Fools' Day

2 SUN

COMMUNITY SERVICE

Did I do C.S. this week? _____

Hours? _____

Verified? _____Y/N_____

SCHOOL PRIDE

Period 1

Period 2

Period 3

Period 4

Period 5

Advisory

DAILY EVENTS

HALL PASS

TO: _____ TO: _____
 TIME: _____ TIME: _____
 INITIALS: _____ INITIALS: _____

TO: _____ TO: _____
 TIME: _____ TIME: _____
 INITIALS: _____ INITIALS: _____

		3 M	4 TU	5 W
Period 1				
Period 2				
Period 3				
Period 4				
Period 5				
Advisory				
DAILY EVENTS				
HALL PASS	TO:	TO:	TO:	TO:
	TIME:	TIME:	TIME:	TIME:
	INITIALS:	INITIALS:	INITIALS:	INITIALS:

Period 1		
Period 2		
Period 3		
Period 4		
Period 5		
Advisory		
DAILY EVENTS		
HALL PASS	TO: _____ TIME: _____ INITIALS: _____	TO: _____ TIME: _____ INITIALS: _____

APRIL	2017	MAY	2017										
S	M	T	W	T	F	S	S	M	T	W	T	F	S
2	3	4	5	6	7	8	1	2	3	4	5	6	
9	10	11	12	13	14	15	7	8	9	10	11	12	13
16	17	18	19	20	21	22	14	15	16	17	18	19	20
23	24	25	26	27	28	29	21	22	23	24	25	26	27
							28	29	30	31			
							30						

"The superior man thinks always of virtue; the common man thinks of comfort." – Confucius

8 SAT

Did I do C.S. this week? _____ Hours? _____ Verified? _____Y/N_____

9 SUN

Palm Sunday

COMMUNITY SERVICE

Did I do C.S. this week? _____

Hours? _____

Verified? _____Y/N_____

SCHOOL PRIDE

		10	M	11	TU	12	W	
Period 1								
Period 2								
Period 3								
Period 4								
Period 5								
Advisory								
DAILY EVENTS	<i>Passover begins at sundown</i>							
HALL PASS	TO:	TO:	TO:	TO:	TO:	TO:	TO:	
	TIME:	TIME:	TIME:	TIME:	TIME:	TIME:	TIME:	
	INITIALS:	INITIALS:	INITIALS:	INITIALS:	INITIALS:	INITIALS:	INITIALS:	

13 TH

14 F

APRIL

Period 1				
Period 2				
Period 3				
Period 4				
Period 5				
Advisory				
DAILY EVENTS				
HALL PASS	TO:	TO:	TO:	TO:
	TIME:	TIME:	TIME:	TIME:
	INITIALS:	INITIALS:	INITIALS:	INITIALS:

APRIL 2017							MAY 2017						
S	M	T	W	T	F	S	S	M	T	W	T	F	S
								1	2	3	4	5	6
2	3	4	5	6	7	8	7	8	9	10	11	12	13
9	10	11	12	13	14	15	14	15	16	17	18	19	20
16	17	18	19	20	21	22	21	22	23	24	25	26	27
23	24	25	26	27	28	29	28	29	30	31			
							30						

A FAIR person is honest and does not show favoritism.

15 SAT

16 SUN

Easter

COMMUNITY SERVICE

Did I do C.S. this week? _____

Hours? _____

Verified? _____ Y/N _____

SCHOOL PRIDE

		17 M	18 TU	19 W
Period 1				
Period 2				
Period 3				
Period 4				
Period 5				
Advisory				
DAILY EVENTS				
HALL PASS	TO:	TO:	TO:	TO:
	TIME:	TIME:	TIME:	TIME:
	INITIALS:	INITIALS:	INITIALS:	INITIALS:

20 TH

21 F

APRIL

Period 1					
Period 2					
Period 3					
Period 4					
Period 5					
Advisory					
DAILY EVENTS					
HALL PASS	TO: _____	TO: _____	TO: _____	TO: _____	
	TIME: _____	TIME: _____	TIME: _____	TIME: _____	
	INITIALS: _____	INITIALS: _____	INITIALS: _____	INITIALS: _____	

APRIL	2017							MAY	2017						
S	M	T	W	T	F	S	S	M	T	W	T	F	S		
							1	1	2	3	4	5	6		
2	3	4	5	6	7	8	7	8	9	10	11	12	13		
9	10	11	12	13	14	15	14	15	16	17	18	19	20		
16	17	18	19	20	21	22	21	22	23	24	25	26	27		
23	24	25	26	27	28	29	28	29	30	31					
30															

You're playing a group trivia game in class and you notice one student who hasn't had a turn to answer. What do you do?

22 SAT

Earth Day

23 SUN

COMMUNITY SERVICE

Did I do C.S. this week? _____

Hours? _____

Verified? _____ Y/N _____

SCHOOL PRIDE

24 M

25 TU

26 W

Period 1

Period 2

Period 3

Period 4

Period 5

Advisory

DAILY EVENTS

HALL PASS

TO:
TIME:
INITIALS:

TO:
TIME:
INITIALS:

TO:
TIME:
INITIALS:

TO:
TIME:
INITIALS:

TO:
TIME:
INITIALS:

TO:
TIME:
INITIALS:

27 TH

28 F

APRIL

Period 1	_____		_____	
	_____		_____	
	_____		_____	
	_____		_____	
	_____		_____	
Period 2	_____		_____	
	_____		_____	
	_____		_____	
	_____		_____	
	_____		_____	
Period 3	_____		_____	
	_____		_____	
	_____		_____	
	_____		_____	
	_____		_____	
Period 4	_____		_____	
	_____		_____	
	_____		_____	
	_____		_____	
	_____		_____	
Period 5	_____		_____	
	_____		_____	
	_____		_____	
	_____		_____	
	_____		_____	
Advisory	_____		_____	
	_____		_____	
	_____		_____	
	_____		_____	
	_____		_____	
DAILY EVENTS	_____		_____	
	_____		_____	
	_____		_____	
	_____		_____	
	_____		_____	
HALL PASS	TO: _____	TO: _____	TO: _____	TO: _____
	TIME: _____	TIME: _____	TIME: _____	TIME: _____
	INITIALS: _____	INITIALS: _____	INITIALS: _____	INITIALS: _____

APRIL							2017							MAY							2017						
S	M	T	W	T	F	S	S	M	T	W	T	F	S	S	M	T	W	T	F	S	S	M	T	W	T	F	S
														1							1	2	3	4	5	6	
2	3	4	5	6	7	8	7	8	9	10	11	12	13	14	15	16	17	18	19	20	21	22	23	24	25	26	27
16	17	18	19	20	21	22	21	22	23	24	25	26	27	28	29	30	31										
23	24	25	26	27	28	29	28	29	30	31																	
30																											

"To be fair is not enough any more. We must be ferociously fair." – John Hay Whitney

29 SAT

30 SUN

COMMUNITY SERVICE

Did I do C.S. this week? _____

Hours? _____

Verified? _____ Y/N _____

SCHOOL PRIDE

		1	M	2	TU	3	W
Period 1							
Period 2							
Period 3							
Period 4							
Period 5							
Advisory							
DAILY EVENTS							
HALL PASS	TO:	TO:	TO:	TO:	TO:	TO:	TO:
	TIME:	TIME:	TIME:	TIME:	TIME:	TIME:	TIME:
	INITIALS:	INITIALS:	INITIALS:	INITIALS:	INITIALS:	INITIALS:	INITIALS:

		4 TH	5 F	MAY																																																								
Period 1				<table border="1" style="font-size: 8px; width: 100%; border-collapse: collapse;"> <thead> <tr> <th colspan="2">MAY</th> <th colspan="2">2017</th> <th colspan="2">JUNE</th> <th colspan="2">2017</th> </tr> <tr> <th>S</th><th>M</th><th>T</th><th>W</th><th>T</th><th>F</th><th>S</th><th>S</th> </tr> </thead> <tbody> <tr> <td>1</td><td>2</td><td>3</td><td>4</td><td>5</td><td>6</td><td></td><td>1 2 3</td> </tr> <tr> <td>7</td><td>8</td><td>9</td><td>10</td><td>11</td><td>12</td><td>13</td><td>4 5 6 7 8 9 10</td> </tr> <tr> <td>14</td><td>15</td><td>16</td><td>17</td><td>18</td><td>19</td><td>20</td><td>11 12 13 14 15 16 17</td> </tr> <tr> <td>21</td><td>22</td><td>23</td><td>24</td><td>25</td><td>26</td><td>27</td><td>18 19 20 21 22 23 24</td> </tr> <tr> <td>28</td><td>29</td><td>30</td><td>31</td><td></td><td></td><td></td><td>25 26 27 28 29 30</td> </tr> </tbody> </table> <p style="text-align: center; margin-top: 10px;">If you TRUST someone, you believe that person is honest and reliable.</p>	MAY		2017		JUNE		2017		S	M	T	W	T	F	S	S	1	2	3	4	5	6		1 2 3	7	8	9	10	11	12	13	4 5 6 7 8 9 10	14	15	16	17	18	19	20	11 12 13 14 15 16 17	21	22	23	24	25	26	27	18 19 20 21 22 23 24	28	29	30	31				25 26 27 28 29 30
MAY		2017			JUNE		2017																																																					
S	M	T	W		T	F	S	S																																																				
1	2	3	4		5	6		1 2 3																																																				
7	8	9	10		11	12	13	4 5 6 7 8 9 10																																																				
14	15	16	17		18	19	20	11 12 13 14 15 16 17																																																				
21	22	23	24	25	26	27	18 19 20 21 22 23 24																																																					
28	29	30	31				25 26 27 28 29 30																																																					
Period 2																																																												
Period 3																																																												
Period 4																																																												
Period 5																																																												
Advisory																																																												
DAILY EVENTS			<i>Cinco de Mayo</i>																																																									
HALL PASS	TO: _____ TIME: _____ INITIALS: _____	TO: _____ TIME: _____ INITIALS: _____	TO: _____ TIME: _____ INITIALS: _____	<div style="background-color: black; color: white; text-align: center; padding: 5px;">6 SAT</div> <div style="background-color: black; color: white; text-align: center; padding: 5px; margin-top: 20px;">7 SUN</div> <div style="background-color: black; color: white; text-align: center; padding: 5px; margin-top: 10px;">COMMUNITY SERVICE</div> Did I do C.S. this week? _____ Hours? _____ Verified? _____Y/N_____ <div style="background-color: black; color: white; text-align: center; padding: 5px; margin-top: 10px;">SCHOOL PRIDE</div>																																																								

		8 M		9 TU		10 W		
Period 1								
Period 2								
Period 3								
Period 4								
Period 5								
Advisory								
DAILY EVENTS								
HALL PASS	TO:	TO:	TO:	TO:	TO:	TO:	TO:	
	TIME:	TIME:	TIME:	TIME:	TIME:	TIME:	TIME:	
	INITIALS:	INITIALS:	INITIALS:	INITIALS:	INITIALS:	INITIALS:	INITIALS:	

11 TH		12 F		MAY																																																																																	
Period 1				<table border="1" style="width: 100%; border-collapse: collapse;"> <thead> <tr> <th style="width: 5%;">MAY</th> <th style="width: 5%;">2017</th> <th style="width: 5%;">JUNE</th> <th style="width: 5%;">2017</th> <th style="width: 5%;">S</th> <th style="width: 5%;">M</th> <th style="width: 5%;">T</th> <th style="width: 5%;">W</th> <th style="width: 5%;">T</th> <th style="width: 5%;">F</th> <th style="width: 5%;">S</th> </tr> </thead> <tbody> <tr> <td>1</td><td>2</td><td>3</td><td>4</td><td>5</td><td>6</td><td></td><td></td><td></td><td></td><td>1</td><td>2</td><td>3</td> </tr> <tr> <td>7</td><td>8</td><td>9</td><td>10</td><td>11</td><td>12</td><td>13</td><td>4</td><td>5</td><td>6</td><td>7</td><td>8</td><td>9</td><td>10</td> </tr> <tr> <td>14</td><td>15</td><td>16</td><td>17</td><td>18</td><td>19</td><td>20</td><td>11</td><td>12</td><td>13</td><td>14</td><td>15</td><td>16</td><td>17</td> </tr> <tr> <td>21</td><td>22</td><td>23</td><td>24</td><td>25</td><td>26</td><td>27</td><td>18</td><td>19</td><td>20</td><td>21</td><td>22</td><td>23</td><td>24</td> </tr> <tr> <td>28</td><td>29</td><td>30</td><td>31</td><td></td><td></td><td></td><td>25</td><td>26</td><td>27</td><td>28</td><td>29</td><td>30</td><td></td> </tr> </tbody> </table>		MAY	2017	JUNE	2017	S	M	T	W	T	F	S	1	2	3	4	5	6					1	2	3	7	8	9	10	11	12	13	4	5	6	7	8	9	10	14	15	16	17	18	19	20	11	12	13	14	15	16	17	21	22	23	24	25	26	27	18	19	20	21	22	23	24	28	29	30	31				25	26	27	28	29	30	
MAY	2017	JUNE	2017	S	M	T	W	T	F	S																																																																											
1	2	3	4	5	6					1	2	3																																																																									
7	8	9	10	11	12	13	4	5	6	7	8	9	10																																																																								
14	15	16	17	18	19	20	11	12	13	14	15	16	17																																																																								
21	22	23	24	25	26	27	18	19	20	21	22	23	24																																																																								
28	29	30	31				25	26	27	28	29	30																																																																									
Period 2				<p>Someone confides in you something they are embarrassed about. How do you react?</p>																																																																																	
Period 3				13 SAT																																																																																	
Period 4				14 SUN																																																																																	
Period 5				<p><i>Mother's Day</i></p>																																																																																	
Advisory				COMMUNITY SERVICE																																																																																	
				<p>Did I do C.S. this week? _____</p> <p>Hours? _____</p> <p>Verified? _____ Y/N _____</p>																																																																																	
DAILY EVENTS				SCHOOL PRIDE																																																																																	
HALL PASS	TO: _____ TIME: _____ INITIALS: _____	TO: _____ TIME: _____ INITIALS: _____	TO: _____ TIME: _____ INITIALS: _____	TO: _____ TIME: _____ INITIALS: _____																																																																																	

		15 M	16 TU	17 W
Period 1				
Period 2				
Period 3				
Period 4				
Period 5				
Advisory				
DAILY EVENTS				
HALL PASS	TO:	TO:	TO:	TO:
	TIME:	TIME:	TIME:	TIME:
	INITIALS:	INITIALS:	INITIALS:	INITIALS:

18 TH

19 F

MAY

Period 1

Period 2

Period 3

Period 4

Period 5

Advisory

DAILY EVENTS

HALL PASS

TO: TIME: INITIALS: TO: TIME: INITIALS:

TO: TIME: INITIALS: TO: TIME: INITIALS:

MAY 2017					JUNE 2017				
S	M	T	W	T	S	M	T	W	T
1	2	3	4	5	6				1
7	8	9	10	11	12	13	4	5	6
14	15	16	17	18	19	20	11	12	13
21	22	23	24	25	26	27	18	19	20
28	29	30	31		25	26	27	28	29

"I can trust my friends.
These people force me to
examine myself, encourage
me to grow." - Cher Bono

20 SAT

21 SUN

COMMUNITY SERVICE

Did I do C.S. this week? _____

Hours? _____

Verified? _____ Y/N _____

SCHOOL PRIDE

		22	M	23	TU	24	W	
Period 1								
Period 2								
Period 3								
Period 4								
Period 5								
Advisory								
DAILY EVENTS								
HALL PASS	TO:	TO:	TO:	TO:	TO:	TO:	TO:	
	TIME:	TIME:	TIME:	TIME:	TIME:	TIME:	TIME:	
	INITIALS:	INITIALS:	INITIALS:	INITIALS:	INITIALS:	INITIALS:	INITIALS:	

25 TH

26 F

MAY

Period 1

Period 2

Period 3

Period 4

Period 5

Advisory

DAILY EVENTS

HALL PASS

TO: _____
 TIME: _____
 INITIALS: _____

TO: _____
 TIME: _____
 INITIALS: _____

TO: _____
 TIME: _____
 INITIALS: _____

TO: _____
 TIME: _____
 INITIALS: _____

Ramadan begins at sundown

MAY		2017		JUNE		2017								
S	M	T	W	T	F	S	S	M	T	W	T	F	S	
1	2	3	4	5	6							1	2	3
7	8	9	10	11	12	13	4	5	6	7	8	9	10	
14	15	16	17	18	19	20	11	12	13	14	15	16	17	
21	22	23	24	25	26	27	18	19	20	21	22	23	24	
28	29	30	31				25	26	27	28	29	30		

SELF-CONTROL means being in command of your feelings and behavior.

27 SAT

28 SUN

COMMUNITY SERVICE

Did I do C.S. this week? _____

Hours? _____

Verified? _____Y/N_____

SCHOOL PRIDE

		29 M	30 TU	31 W
Period 1				
Period 2				
Period 3				
Period 4				
Period 5				
Advisory				
DAILY EVENTS	Memorial Day (Observed)			
HALL PASS	TO:	TO:	TO:	TO:
	TIME:	TIME:	TIME:	TIME:
	INITIALS:	INITIALS:	INITIALS:	INITIALS:

		1 TH	2 F	MAY																																																																																												
Period 1				<table border="1" style="width: 100%; border-collapse: collapse;"> <thead> <tr> <th style="width: 10%;">MAY</th> <th style="width: 10%;">2017</th> <th style="width: 10%;">JUNE</th> <th style="width: 10%;">2017</th> <th style="width: 10%;">MAY</th> <th style="width: 10%;">2017</th> </tr> </thead> <tbody> <tr> <td>S</td><td>M</td><td>T</td><td>W</td><td>T</td><td>F</td><td>S</td> <td>S</td><td>M</td><td>T</td><td>W</td><td>T</td><td>F</td><td>S</td> </tr> <tr> <td>1</td><td>2</td><td>3</td><td>4</td><td>5</td><td>6</td><td></td> <td></td><td></td><td></td><td></td><td></td><td>1</td><td>2</td><td>3</td> </tr> <tr> <td>7</td><td>8</td><td>9</td><td>10</td><td>11</td><td>12</td><td>13</td> <td>4</td><td>5</td><td>6</td><td>7</td><td>8</td><td>9</td><td>10</td> </tr> <tr> <td>14</td><td>15</td><td>16</td><td>17</td><td>18</td><td>19</td><td>20</td> <td>11</td><td>12</td><td>13</td><td>14</td><td>15</td><td>16</td><td>17</td> </tr> <tr> <td>21</td><td>22</td><td>23</td><td>24</td><td>25</td><td>26</td><td>27</td> <td>18</td><td>19</td><td>20</td><td>21</td><td>22</td><td>23</td><td>24</td> </tr> <tr> <td>28</td><td>29</td><td>30</td><td>31</td><td></td><td></td><td></td> <td>25</td><td>26</td><td>27</td><td>28</td><td>29</td><td>30</td><td></td> </tr> </tbody> </table>		MAY	2017	JUNE	2017	MAY	2017	S	M	T	W	T	F	S	S	M	T	W	T	F	S	1	2	3	4	5	6							1	2	3	7	8	9	10	11	12	13	4	5	6	7	8	9	10	14	15	16	17	18	19	20	11	12	13	14	15	16	17	21	22	23	24	25	26	27	18	19	20	21	22	23	24	28	29	30	31				25	26	27	28	29	30	
MAY	2017	JUNE	2017	MAY	2017																																																																																											
S	M	T	W	T	F	S	S	M	T	W	T	F	S																																																																																			
1	2	3	4	5	6							1	2	3																																																																																		
7	8	9	10	11	12	13	4	5	6	7	8	9	10																																																																																			
14	15	16	17	18	19	20	11	12	13	14	15	16	17																																																																																			
21	22	23	24	25	26	27	18	19	20	21	22	23	24																																																																																			
28	29	30	31				25	26	27	28	29	30																																																																																				
Period 2				3 SAT																																																																																												
Period 3																																																																																																
Period 4																																																																																																
Period 5																																																																																																
Advisory				4 SUN																																																																																												
DAILY EVENTS				COMMUNITY SERVICE																																																																																												
HALL PASS	TO: _____ TIME: _____ INITIALS: _____	TO: _____ TIME: _____ INITIALS: _____	TO: _____ TIME: _____ INITIALS: _____	TO: _____ TIME: _____ INITIALS: _____	Did I do C.S. this week? _____ Hours? _____ Verified? _____Y/N_____																																																																																											
					SCHOOL PRIDE																																																																																											

		5 M	6 TU	7 W
Period 1				
Period 2				
Period 3				
Period 4				
Period 5				
Advisory				
DAILY EVENTS				
HALL PASS	TO:	TO:	TO:	TO:
	TIME:	TIME:	TIME:	TIME:
	INITIALS:	INITIALS:	INITIALS:	INITIALS:

Period 1		
Period 2		
Period 3		
Period 4		
Period 5		
Advisory		
DAILY EVENTS		
HALL PASS	TO: _____ TIME: _____ INITIALS: _____	TO: _____ TIME: _____ INITIALS: _____

JUNE		2017		JULY		2017							
S	M	T	W	T	F	S	S	M	T	W	T	F	S
			1	2	3								1
4	5	6	7	8	9	10	2	3	4	5	6	7	8
11	12	13	14	15	16	17	9	10	11	12	13	14	15
18	19	20	21	22	23	24	16	17	18	19	20	21	22
25	26	27	28	29	30		23	24	25	26	27	28	29
							30	31					

"Prudent, cautious self-control is wisdom's root." – Robert Burns

10 SAT

11 SUN

COMMUNITY SERVICE

Did I do C.S. this week? _____

Hours? _____

Verified? _____ Y/N _____

SCHOOL PRIDE

JUNE 2017

MONDAY

TUESDAY

WEDNESDAY

5

6

7

12

13

Flag Day

14

19

Laylat al-Qadr begins at sundown

20

First Day of Summer

21

26

27

28

THURSDAY

1

FRIDAY

2

SATURDAY / SUNDAY

3

4

8

9

10

11

15

16

17

Father's Day

18

22

23

24

Eid al-Fitr begins at sundown

25

29

30

JULY 2017

MONDAY

TUESDAY

WEDNESDAY

3

Independence Day

4

5

10

11

12

17

18

19

24

25

26

31

THURSDAY

FRIDAY

SATURDAY / SUNDAY

1

2

6

7

8

9

13

14

15

16

20

21

22

23

27

28

29

30

AUGUST 2017

MONDAY	TUESDAY	WEDNESDAY
	1	2
7	8	9
14	15	16
21	22	23
28	29	30

THURSDAY

FRIDAY

SATURDAY / SUNDAY

3

4

5

6

10

11

12

13

17

18

19

20

24

25

26

27

31

LANGUAGE ARTS {frequently misspelled words}

absence	cinnamon	enough	here	obedience	reference	therefore
absorb	climbed	entertain	history	occasion	referring	they
accept	climbing	envelope	hoping	occur	rein	they're
accidentally	clothes	equipment	hospital	occurred	reign	thief
accompany	colonel	equipped	humor	occurrence	relative	thoroughly
accuse	college	escape	humorous	occurring	relief	thought
ache	column	especially	hungry	often	religion	through
achieve	commercial	etc.	identify	opinion	remember	tobacco
acquaintance	committee	everybody	imagine	opportunity	repetition	together
acquire	completely	everywhere	immediate	opposite	repellent	tomorrow
affect	concentrate	exaggerate	immediately	original	reservoir	tragedy
afraid	conscientious	exceed	immensely	other	restaurant	tried
against	conscious	excellence	incident	pageant	rhyme	trouble
aggression	continue	excellent	independent	pamphlet	rhythm	truly
aggressive	continuous	except	Indian	parallel	ridiculous	two
all right	convenience	excitement	innocent	parents	running	unique
a lot	convenient	exciting	instead	parliament	safety	until
already	counterfeit	existence	intelligence	particular	Saturday	unusual
always	countries	expense	intelligent	passed	scent	usually
amateur	courage	experiment	interpret	peculiar	schedule	vaccinate
ambition	courageous	experience	interrupt	perform	scissors	vacuum
among	courteous	familiar	introduce	permanent	search	vegetable
apology	cried	families	its	persuade	secret	village
apparent	criticism	fasten	it's	phenomenon	secretary	villain
appearance	criticize	fatigue	jealous	piece	semester	weather
appreciate	curiosity	favorite	knew	pilot	sense	Wednesday
arctic	debt	fiction	know	plain	separate	weight
argument	deceive	fictitious	knowledge	plane	separation	weird
article	decide	field	laboratory	planned	sergeant	were
associate	definite	finally	laid	pleasant	shepherd	we're
athlete	definitely	first	leisure	poison	shining	where
attendance	descend	forecast	library	possess	sincerely	whether
attitude	describe	foreign	lightning	possession	soldier	which
author	description	foresee	literature	possible	sophomore	whole
awful	desert	forest	lonely	practically	spaghetti	whose
beautiful	dessert	foretell	loose	prairie	speak	witch
beauty	destroy	formerly	lying	precede	speech	woman
because	develop	forty	magazine	preferred	sponsor	women
beginning	dictionary	fragile	magnificent	prejudice	squirrel	wonderful
believe	didn't	freight	many	preparation	stationery	wreck
benefit	difficult	friend	marriage	principal	stepping	writing
bicycle	dinner	front	mathematics	principle	stopping	written
biscuit	dining	fulfill	meant	privilege	stories	wrote
boundary	disappear	government	medicine	probably	strengthen	yolk
Britain	disappoint	governor	millionaire	profession	stretch	your
brilliance	discipline	grabbed	miniature	prophecy	studies	you're
brilliant	discussion	grammar	minute	psychologist	studying	
bureau	disease	grateful	mischievous	psychology	succeed	
business	dissatisfy	guard	model	pursue	successful	
captain	doctor	guarantee	mosquito	suggest	suggest	
career	does	guess	narrative	summary	summarize	
carrying	doesn't	guest	necessary	superintendent	summary	
cemetery	dropping	handsome	neighbor	suspense	superintendent	
certain	during	happen	nervous	suspicion	suspense	
challenge	easier	happiest	niece	swimming	suspicion	
chief	easiest	happily	nineteen	synagogue	receive	
children	easily	happiness	ninety	temperament	receiving	
chocolate	effect	hear	notice	there	recess	
chosen	either	height	noticeable	recognize	recognize	
Christian	embarrass		nuisance	recommend	recommend	



SCIENCE {periodic table of the elements}

1* IA**		2 IIA		Transition Metals										13 IIIA		14 IVA		15 VA		16 VIA		17 VIIA		18 VIIIA											
Atomic Number		Atomic Mass		Symbol of the Element		Element Name																													
1	H Hydrogen 1.008	2	He Helium 4.003	3	Li Lithium 6.941(2)	4	Be Beryllium 9.012	5	B Boron 10.81	6	C Carbon 12.01	7	N Nitrogen 14.01	8	O Oxygen 16.00	9	F Fluorine 19.00	10	Ne Neon 20.18	11	Na Sodium 22.99	12	Mg Magnesium 24.31	13	Al Aluminum 26.98	14	Si Silicon 28.09	15	P Phosphorus 30.97	16	S Sulfur 32.07	17	Cl Chlorine 35.45	18	Ar Argon 39.95
19	K Potassium 39.10	20	Ca Calcium 40.08	21	Sc Scandium 44.96	22	Ti Titanium 47.87	23	V Vanadium 50.94	24	Cr Chromium 52.00	25	Mn Manganese 54.94	26	Fe Iron 55.85	27	Co Cobalt 58.93	28	Ni Nickel 58.69	29	Cu Copper 63.55	30	Zn Zinc 65.38(2)	31	Ga Gallium 69.72	32	Ge Germanium 72.64	33	As Arsenic 74.92	34	Se Selenium 78.96(3)	35	Br Bromine 79.90	36	Kr Krypton 83.80
37	Rb Rubidium 85.47	38	Sr Strontium 87.62	39	Y Yttrium 88.91	40	Zr Zirconium 91.22	41	Nb Niobium 92.91	42	Mo Molybdenum 95.96(2)	43	Tc Technetium 98	44	Ru Ruthenium 101.1	45	Rh Rhodium 102.9	46	Pd Palladium 106.4	47	Ag Silver 107.9	48	Cd Cadmium 112.4	49	In Indium 114.8	50	Sn Tin 118.7	51	Sb Antimony 121.8	52	Te Tellurium 127.6	53	I Iodine 126.9	54	Xe Xenon 131.3
55	Cs Cesium 132.9	56	Ba Barium 137.3	57	# Lanthanoid Series	58	La Lanthanum 138.9	59	Ce Cerium 140.1	60	Pr Praseodymium 140.9	61	Pm Promethium 144.2	62	Sm Samarium 150.4	63	Eu Europium 152.0	64	Gd Gadolinium 157.3	65	Tb Terbium 158.9	66	Dy Dysprosium 162.5	67	Ho Holmium 164.9	68	Er Erbium 167.3	69	Tm Thulium 168.9	70	Yb Ytterbium 173.1	71	Lu Lutetium 175.0		
87	Fr Francium (223)	88	Ra Radium (226)	89	Ac Actinoid Series	90	Th Thorium 232.0	91	Pa Protactinium 231.0	92	U Uranium 238.0	93	Np Neptunium (237)	94	Pu Plutonium (244)	95	Am Americium (243)	96	Cm Curium (247)	97	Bk Berkelium (247)	98	Cf Californium (251)	99	Es Einsteinium (252)	100	Fm Fermium (257)	101	Md Mendelevium (258)	102	No Nobelium (259)	103	Lr Lawrencium (262)		

Group IA (excluding Hydrogen) comprises the alkali metals.
Group IIA comprises the alkaline-earth metals.
Group VIIIA comprises the noble gases.

Transition Metals

Notes: *Numbering system adopted by IUPAC.

**Numbering system widely used from the mid-20th century.

For elements with no stable isotopes, the mass number of the isotope with the longest half-life is in parentheses.

Discoveries of elements 113, 115, 117, and 118 are claimed but not confirmed. Element names are temporarily assigned.

This table is as of May 1, 2013.

Source: The International Union of Pure and Applied Chemistry (IUPAC), Encyclopædia Britannica, and others

MATHEMATICS {geometric angles & congruency cases}

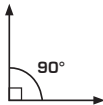
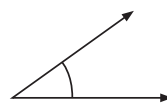
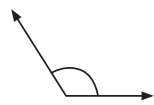
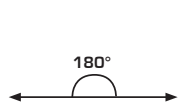
GEOMETRIC ANGLES			
 <p>A right angle is exactly 90°</p>	 <p>An acute angle is less than 90°</p>	 <p>An obtuse angle is greater than 90°</p>	 <p>A straight angle is exactly 180°</p>

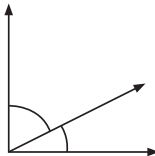
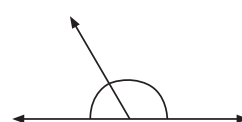
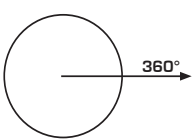
 <p>Complementary angles add up to 90°</p>	 <p>Supplementary angles add up to 180°</p>	 <p>One complete angle of rotation = 360°</p>
---	--	--

GEOMETRIC CONGRUENCY CASES

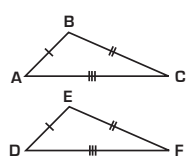
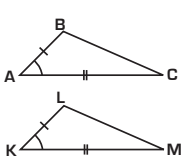
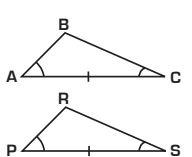
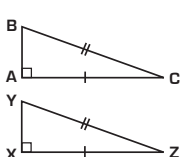
S.S.S. POSTULATE	S.A.S. POSTULATE	A.S.A. POSTULATE	H.S. POSTULATE (RIGHT Δ 'S ONLY)
 <p>Side-Side-Side $\triangle ABC \cong \triangle DEF$</p>	 <p>Side-Angle-Side $\triangle ABC = \triangle KLM$</p>	 <p>Angle-Side-Angle $\triangle ABC = \triangle PRS$</p>	 <p>Hypotenuse-side $\triangle ABC = \triangle XYZ$</p>

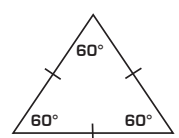
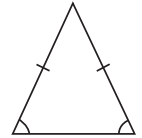
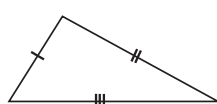
EQUILATERAL TRIANGLE	ISOSCELES TRIANGLE	SCALENE TRIANGLE
 <p>3 Sides of Equal Length 3 Angles of 60° Each</p>	 <p>2 Sides of Equal Length 2 Base Angles are Equal</p>	 <p>3 Unequal Sides 3 Unequal Angles</p>

GEOGRAPHY {world map}

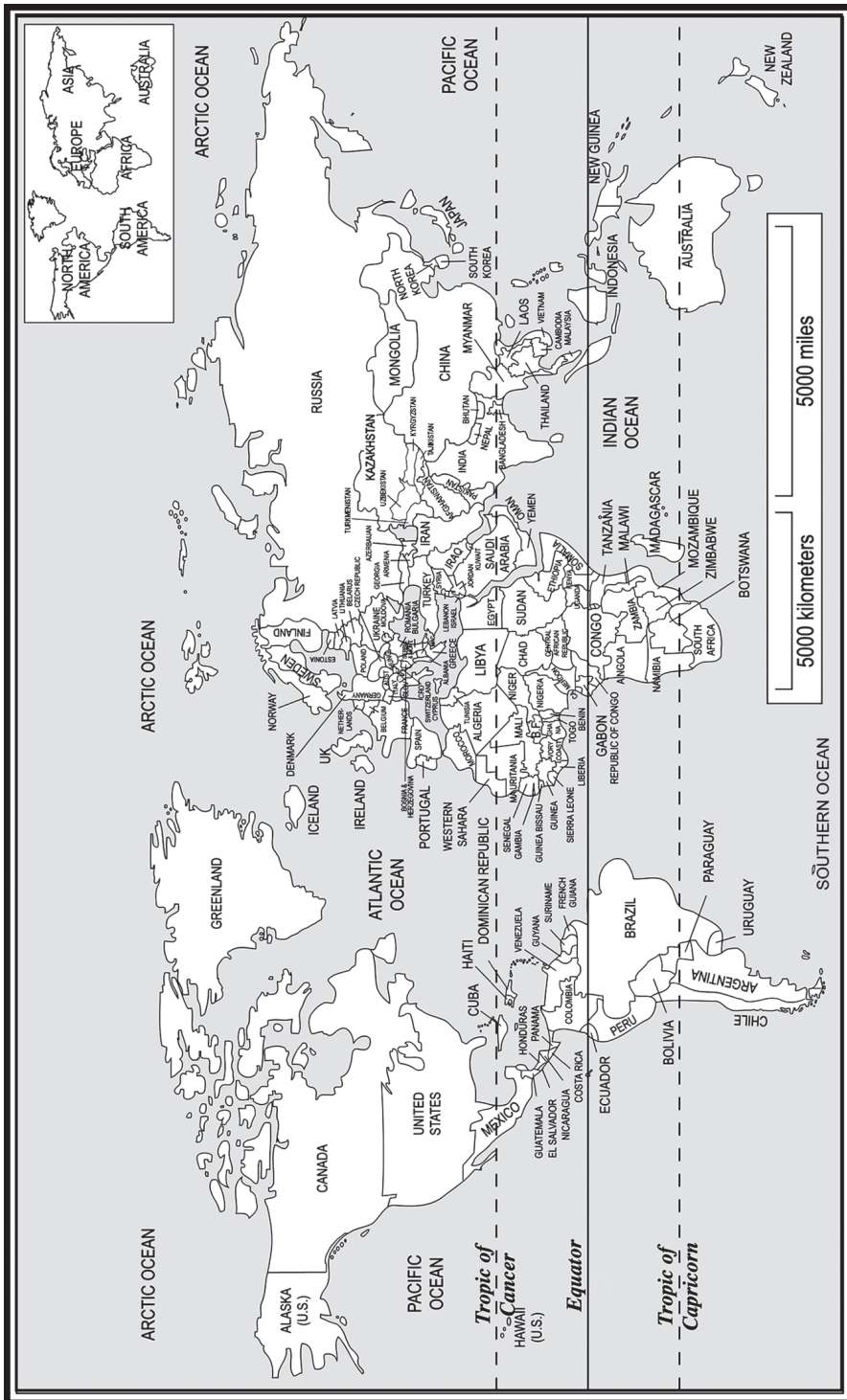

Restroom Passes

Term 1 Semester 1

	DATE	TIME	TEACHER	SIGNATURE
Period 1				
Period 1				
Period 1				

	DATE	TIME	TEACHER	SIGNATURE
Period 2				
Period 2				
Period 2				

	DATE	TIME	TEACHER	SIGNATURE
Period 3				
Period 3				
Period 3				

	DATE	TIME	TEACHER	SIGNATURE
Period 4				
Period 4				
Period 4				

	DATE	TIME	TEACHER	SIGNATURE
Period 5				
Period 5				
Period 5				

During Advisory students are not allowed to use Bathroom**

Students are NOT eligible to use passes during the first 15 minutes or last 15 minutes of a period**

Restroom Passes

Term 1 Semester 2

	DATE	TIME	TEACHER	SIGNATURE
Period 1				
Period 1				
Period 1				

	DATE	TIME	TEACHER	SIGNATURE
Period 2				
Period 2				
Period 2				

	DATE	TIME	TEACHER	SIGNATURE
Period 3				
Period 3				
Period 3				

	DATE	TIME	TEACHER	SIGNATURE
Period 4				
Period 4				
Period 4				

	DATE	TIME	TEACHER	SIGNATURE
Period 5				
Period 5				
Period 5				

During Advisory students are not allowed to use Bathroom**

Students are NOT eligible to use passes during the first 15 minutes or last 15 minutes of a period**

Restroom Passes

Term 2 Semester 1

	DATE	TIME	TEACHER	SIGNATURE
Period 1				
Period 1				
Period 1				

	DATE	TIME	TEACHER	SIGNATURE
Period 2				
Period 2				
Period 2				

	DATE	TIME	TEACHER	SIGNATURE
Period 3				
Period 3				
Period 3				

	DATE	TIME	TEACHER	SIGNATURE
Period 4				
Period 4				
Period 4				

	DATE	TIME	TEACHER	SIGNATURE
Period 5				
Period 5				
Period 5				

During Advisory students are not allowed to use Bathroom**

Students are NOT eligible to use passes during the first 15 minutes or last 15 minutes of a period**

Restroom Passes

Term 2 Semester 2

	DATE	TIME	TEACHER	SIGNATURE
Period 1				
Period 1				
Period 1				

	DATE	TIME	TEACHER	SIGNATURE
Period 2				
Period 2				
Period 2				

	DATE	TIME	TEACHER	SIGNATURE
Period 3				
Period 3				
Period 3				

	DATE	TIME	TEACHER	SIGNATURE
Period 4				
Period 4				
Period 4				

	DATE	TIME	TEACHER	SIGNATURE
Period 5				
Period 5				
Period 5				

During Advisory students are not allowed to use Bathroom**

Students are NOT eligible to use passes during the first 15 minutes or last 15 minutes of a period**